



XSTREAM

SERVICE MANUAL V3.3

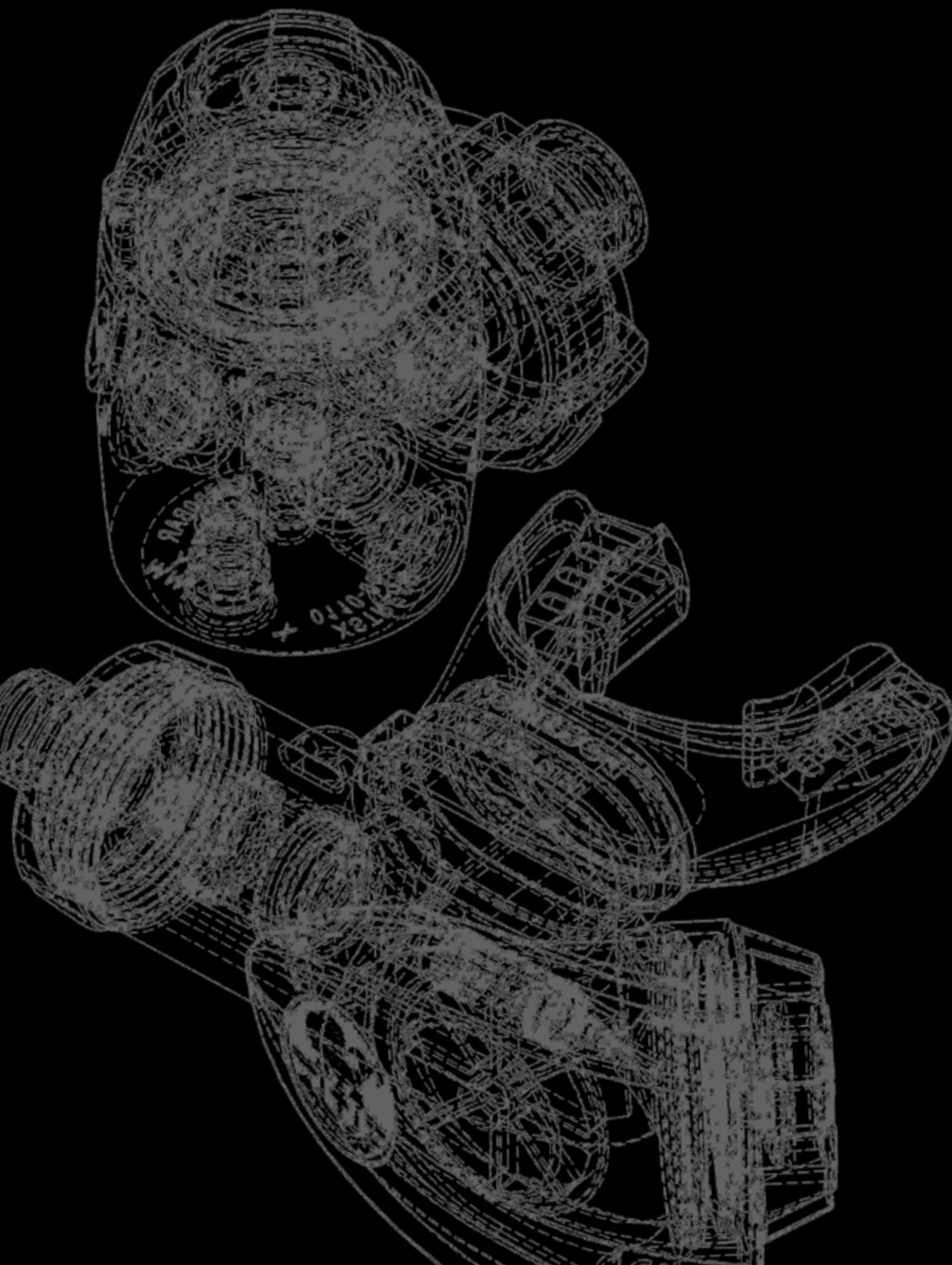



Table of contents

1. Safety regulations	2
2. Introduction	3
Markings	3
Service handbook	5
Symbols used throughout the handbook	5
Improvements	5
Product upgrades	6
Information about Xstream Upgrade kit 4826	6
Information about Xstream 1st stage covers.	6
Information about Xstream Upgrade to cover with adjustment screw.	6
Recommendations	6
EN 144-3	6
Article number on o-rings	6
3. Determination of required service	7
4. Tools	8
5. Spare parts & service kits	8
Second stages	8
First stage bottom mounted	9
First stage 90	10
First stage 90 EAN40	11
First stage Black	12
First stage Yoke	13
Servicekits	14
Upgrade kits	15
Xstream Upgrade Kit	15
Xstream EN 144-3 upgrade kits	15
O-ring conversion table	16
6. Service	17
Disassembly	17
Xstream first stage	17
Xstream second stage	22
Inspections	24
Cleaning	26
Xstream Deep/Dive/Deep EAN40 Cleaning	26
Xstream Deep EAN40	26
0000-149 Ruby Ball Xstream	26
Xstream Deco/Duration Cleaning for Oxygen Use	26
The cleanroom area and work environment requirements	27
Preparations and Pre-cleaning	27
Cleaning	27
Rinsing and drying in the cleanroom	27
Verification	28
Assembly	28
Xstream first stage	28
Xstream second stage	35
7. Final inspection	38
Setting, final inspection	38
Method for regulators cleaned for EAN40 and oxygen use	38
Method for all other regulators	39
8. Technical data	41
Torque table	41
Product data	41
Conversion tables	42
Performance	43
Work of breathing	43
Breathing curve	43
9. Oxygen statement	44
10. Updates	45
APPENDIX A	46
FAQ(T)'s	46
APPENDIX B	47
Fundamental oxygen risks comprehension	47
The O ₄ concept	47
APPENDIX C	48
Intermediate pressure clarification	48
APPENDIX D	49
Cleanroom and oxygen cleaning requirement	49
Check list	49

1. Safety regulations

 The instructions in this handbook must be followed in detail step by step. Negligence can cause serious injury or even death.

Special warnings are marked with this symbol 

 Xstream Deco and Xstream Duration manufactured prior to 2015-01-01, are designed to be used with gasses that has elevated oxygen content. This requires special procedures while servicing; to clean the regulator and to keep it clean. Negligence to follow the instructions given in this manual introduces a risk for the customer of having a fire which in turn can cause serious injury or even death. Servicing the above-mentioned regulators, shall always be conducted in a clean environment using clean tools, as described in section 6 and in Appendix B.

 To enhance safety during servicing, the regulators Xstream Deco and Xstream Duration shall be tested using clean air according to specification in 8. There is no need to test regulators in the servicing environment using gases with > 21% oxygen.

 Starting with serial number 1500001 Xstream Deep is manufactured to be Nitrox Read out of the box. This means that all nitril o-rings have been replaced with EPDM and/or Viton o-rings and only oxygen compatible lubricants have been used during manufacturing. If the Nitrox Ready status is to be maintained after servicing, only service kit marked with EAN40 and oxygen compatible lubricant may be used.

 Servicing must only be carried out by persons who have been trained and certified by Poseidon. Servicing Xstream Deco and Xstream Duration requires an additional certification as "POSEIDON OXYGEN TECHNICIAN"









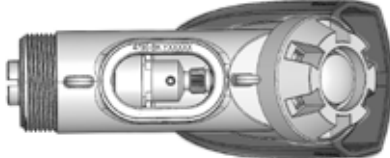

 Only POSEIDON original parts may be used for servicing. Where stated, POSEIDON original tools must be used.

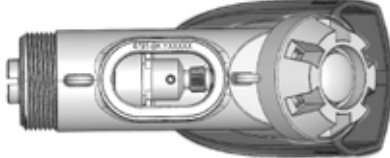

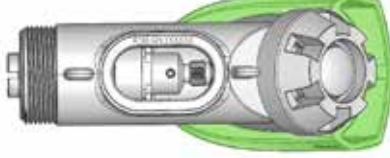

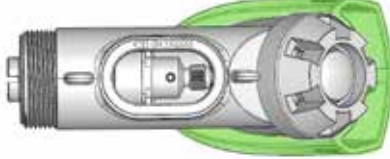
 **WARNING:** Availability of sub-assemblies and components, repair parts, specialized tools and maintenance manuals does not imply qualification to assemble and/or service Poseidon Diving Systems equipment. Improper service of dive equipment can lead to serious injury or death.

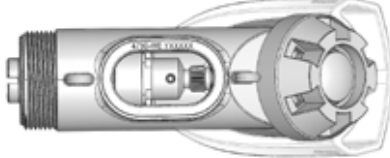
2. Introduction

Markings

This manual contains service and repair instructions and product information for the Poseidon Xstream regulator series. The different Xstream regulator models are most clearly identified by their color. There is always a possibility that the customer has altered the colors himself, why it is important always to check the permanently marked article number as part of the identification of the product. The pictures below show where to find the article and serial number:

1st stages	2nd stages
4790-BK / 002-10 Xstream Deep / Xstream Deep (4+1) 	0120-000 Xstream 9/16 Deep 
4791-BK / 001-47 / 0110-000 Xstream Deep90 / Xstream Deep90 (5+2) / Xstream Deep Mk3 	
4790-GN/ 002-13 /4882-GN Xstream Duration/Xstream Duration(4+1)/Xstream Duration EN 144-3 	0120-001 2:nd Stage Xstream 9/16 Duration 
4791-GN/ 001-87 /4881-GN / 0110-001 / 0110-003 Xstream Duration M26 / G 5/8 	
4790-WE/ 002-16 /4882-WE Xstream Deco G 5/8 / M26 	Xstream Deco 
4791-GY Xstream Dive90 	Xstream Dive 90 

1st stages	2nd stages
<p data-bbox="161 174 767 203">0110-002 - Xstream Oxygen (Only sold with SE7EN EU)</p> 	
	<p data-bbox="834 474 1441 504">4792-YW / 0120-003 2:nd Stage Xstream 9/16, Octopus</p> 
<p data-bbox="161 707 456 736">0110-010 Xstream Black</p>	<p data-bbox="834 707 1190 736">0120-010 Xstream Black 9/16</p>
	

- CE 0120 Meets or exceeds requirements in EU Directive 89/686/EEC, Personal Protective Equipment. Manufacturing assessment carried out by notified body SGS Yarsley, ID no. 0120.
- 0100-000 Model identification
- E.g 200001 or 1200001 Serial number, 6 or 7 digit, first or first two digits denotes year of manufacture. 2 = 2002 / 12 = 2012
- WP 300bar Working pressure 300 bar
- Oxygen Approved for use with 99.95% oxygen
- Nitrox 50% Approved for use with maximum 50% oxygen
- Nitrox Ready Approved for use with EAN40 max

Service handbook

This servicing handbook is available for download at the Poseidon Extranet at <http://extranet.poseidon.se>. Make sure you have the latest issue before undertaking any servicing. The handbook is available in English only.

Further assistance can be reached between 8:00 am to 4:30 pm (GMT+1) at Poseidon Diving Systems:

Phone: +46 (0)31 7342900 ask for "technical assistance"

Fax: +46 (0)31 7342901

e-mail: info@poseidon.se

Symbols used throughout the handbook

Icon	Description	Other information
	Remove the old part. Destroy and give back to customer	
	Replace with new part	
	Visually inspect	
 1	Poseidon grease #1, article no 8515	 8515 Oxygen grease 1
 R	Poseidon grease #R, article no 8516	 8516 Regulator grease
	Warning. Negligence can cause serious injury or even death.	

Improvements

Poseidon has made several improvements, all introduced 2003 starting with serial number 310001.

Starting in 2006, all Xstream 1st stages are equipped with an adjustment screw cover. Older versions with no adjustment screws should be upgraded.

Starting in 2009, all Xstream 90 model first stages are equipped with a built-in over pressure valve.

Starting 2015-01-01, all Xstream Deep 1st stages/regulators are Nitrox (EAN 40) ready out of the box.

Product upgrades

Regulators with serial numbers less than 310001 are subject to a mandatory update programme. To obtain updated replacement parts, order the kit 4826 and submit to Poseidon the serial number of the regulator by sending an email to service@poseidon.com with the serial number and date of service clearly marked.

Regulators fulfilling these criteria shall have the following parts replaced on its first service:

- 4560 replaced by 4760 Seat holder. Seats on regulators numbered after 310001 are different and will not fit older seat holders.
- 4577 replaced by 4777 Lower pin-guide. The part has been changed to withstand a greater torque.
- 4562 replaced by 4762 Upper centre piece. The part has been changed to correspond to the change of 4577
- 4581 Washer. The part has been changed to ease assembly through a more precise fit.
- 0015-012 (4423) O-ring
- 4563 Pin bushing 1st stage Xstream

Information about Xstream Upgrade kit 4826

4760 Seat holder and 4581 Washer are not critical parts to replace, however old seat holders will not fit new seats and is therefore included in the Update kit Xstream at a special price. 4777 Lower pin-guide and 4762 Upper centre piece should be replaced and is therefore included in the kit at no cost.

Information about Xstream 1st stage covers.

During 2006, we began manufacturing Xstream DEEP, DEEP90, DURATION, DURATION90 and DECO 1st stages with chrome colored 1st stage covers with an adjustment screw. Starting January 2007, all Xstream 1st stages, regardless of model/version, will have a chrome-colored 1st stage cover with an adjustment screw.

Information about Xstream Upgrade to cover with adjustment screw.

Any Xstream 1st stages that don't have a cover with an adjustment screw should be upgraded with a cover that has an adjustment screw. This upgrade is not mandatory but recommended.

The upgrade is made using the "Xstream Adjustable kit" (4767-KIT) that contains the following parts:

- 1 x 0000-140 Xstream cover
- 1 x 0000-141 Adjustment screw
- 1 x 4763 Adjustment spring
- 1 x 4764 Seat spring

All these parts must be replaced when upgrading the 1st stage!

Recommendations

For regulators with serial numbers less than 310001 we recommend you offer the customer to upgrade the old type valve housing nut to the improved version with article number 4547. This will significantly reduce the inhalation effort. However, if the customer chooses to keep his old valve housing nut it is perfectly safe to do so.

EN 144-3

Xstream Deco, Xstream Duration and Xstream Duration90 are available also in EN 144-3 configurations, i.e., regulators which comply with the new EN 144-3 standard. See page 3 for correct article numbers.

Older Xstream models can be upgraded to comply with the same standard using an EN 144-3 upgrade kit. See Spare Parts lists on page 13 for details.

Article number on o-rings

In this revision of the service manual, all o-ring article numbers have been updated to match the current article number system used by Poseidon. A conversion list between the old and new o-ring article numbers can be found on page 15.

Nitrox ready (EAN40)

Xstream Deep regulators with serial number 1500001 and later are Nitrox (EAN 40) ready from the manufacturer. The 4822 Servicekit Xstr 1st Deep/Dive 90 and 4825 Servicekit Xstream 2st, all models are EAN 40 compatible.

Xstream Yoke

Xstream 1st stages with fixed yoke connection instead of DIN connection. Introduced in September 2023.

3. Determination of required service

It's recommended that the Xstream regulator is serviced once every 24 months or once every 100 dives, whichever comes first.

It's recommended that low pressure hoses are replaced once every four (4) years to avoid LP hose failures due to wear and tear.

If water has entered a first stage (or suspicion there of), the first stage should be disassembled, cleaned and dried before diving with it again. Water inside the 1st stage can cause corrosion or damage that has a negative effect on the functionality of the 1st stage.













Xstream Deep 1st stages and regulators with serial number 1500001 or higher come Nitrox Ready (EAN 40) out of the box. To maintain this status, the latest service kit revision must be used and only oxygen compatible lubricants applied. Testing and adjusting must be made using gas filtered in accordance with the EAN standard.

Xstream Deep 90 1st stages and regulators with serial numbers lower than 1500001 can be serviced to reach Nitrox Ready level if the following actions are taken:

- All 1st stage components made out of metal are washed in an ultra sonic cleaner for a time period of 10 - 15 minutes.
- Service kits 4822 and 4825 are used for the 1st and 2nd stage.
- Only Poseidon oxygen compatible lubricant (part number 8515) is used
- Gas filtered according to the EAN standard is used for testing/adjusting.

4. Tools

To service Poseidon regulators there are a number of tools required. Some of the tools are special tools for Xstream and Poseidon and some tools are standard tools available in most hardware stores. Below you will find a list of all tools needed, with a description of what it is used for. Note that tools intended to be used for Nitrox approved and O2 clean equipment should be kept separate to avoid contamination.

Item	Description	Xstream	Picture
2297 O-ring remover	Used to remove o-rings.	o	
Open end wrench 6, 13-23 mm	Various open end wrenches in millimeters are essential for assembly and disassembly of various things.	o	
3460 Regulator test	Used to check or finally adjust the regulator.	o	
Ultra Sonic Cleaner	Used to clean all regulators. Mandatory for Xstream Deco and Duration.	o	
3773 Torque wrench set	Used to set the torque on various parts of the regulator.	o	
Allen key 2,5 mm, 4mm, 5 mm, 6 mm	Used to unscrew blindplugs and to adjust IP on Xstream.	o	
2706 Allen key 1,5 mm	Used to untighten and tighten the locking screw on Jetstream and Xstream valve tube and stopscrews on most first stages.	o	
3605 Combination tool 1	Used to screw and unscrew various parts on the Xstream second stages.	o	
3606 Combination tool 2	Used to screw and unscrew various parts on the first stage and second stages.	o	
2705 Adjusting tool	Used to adjust the cracking pressure on Xstream second stages.	o	
4591 17 mm torque wrench	Used to untighten and tighten the connection stem on Xstream first stages.	o	
Articles of consumption			
8515 Oxygen grease #1	Only approved oxygen grease when lubricating oxygen critical parts on the high pressure side. Approved for 300 bar 60°C.	o	
8516 Regulator grease	Used for lubrication of air version regulators.	o	

5. Spare parts & service kits

Second stages

4670-BK	Second stage Xstream Deep	0120-000	Second stage Xstream Deep
4670-GN	Second stage Xstream Duration	0120-001	Second stage Xstream Duration
4670-WE	Second stage Xstream Deco	0120-002	Second stage Xstream Deco
4670-GY	Second stage Xstream Dive	0120-003	Second stage Xstream Octopus
4670-YW	Second stage Xstream Octopus	0120-010	Second stage Xstream Black

Item #	Description
4536	Diaphragm cover
4533	Diaphragm, silicone
4538-BK	Cover Xstream 2nd stage (Deep)
4538-WE	Cover Xstream 2nd stage (Deco)
4538-GN	Cover Xstream 2nd stage (Duration)
4538-YW	Cover Xstream 2nd stage (Octopus)
4538-GY	Cover Xstream 2nd stage (Dive)
4538-BL	Cover Xstream 2nd stage (Black)
4539	Sticker Poseidon Xstream
0000-641	Poseidon Dome Label Black / grey
4531	Checkvalve
4537-BK	Housing Black
4537-WE	Housing White
4537-GY	Housing Grey
0011-278	O-ring Xstream 2nd st., viton
0010-025	O-ring
2857	LP-valve housing
3440	Valve insert
0013-009	O-ring 2nd stage Xstream, EPDM
4547	Valve housing nut, Xstream
2787	Rubber plate
2875	Stop screw
1167	Locking strap
4532	Mouthpiece AIR
0013-351	O-ring 2nd stage Xstream, EPDM
4534	Valve tube Xstream
0013-001	O-ring 2nd stage Xstream, EPDM
4545	Servo-valve Xstream

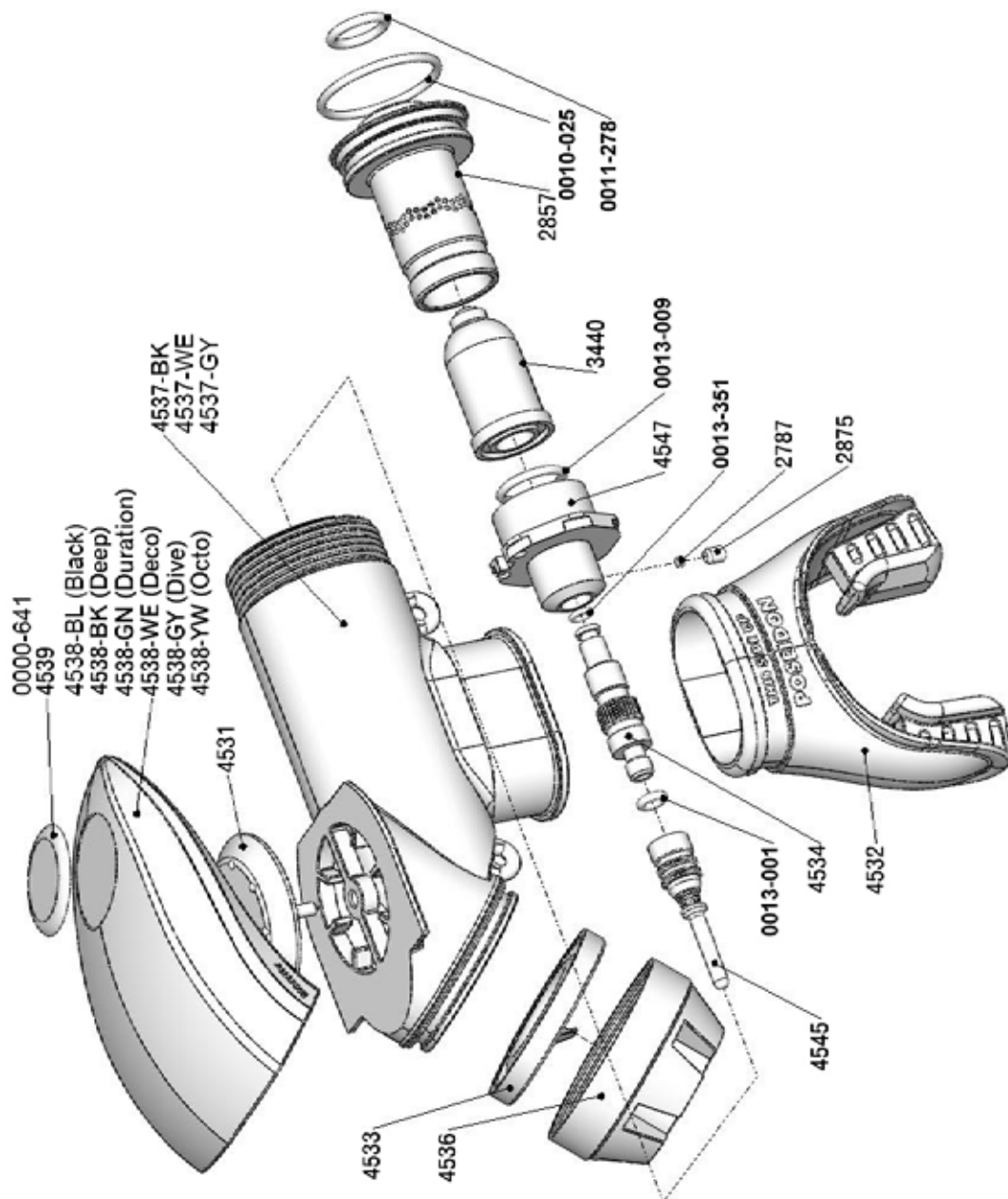

First stage bottom mounted

4780-BK	1st stage G 5/8" Xstream DEEP	002-09	1st stage G 5/8" Xstream DEEP (4+1)
4780-GN	1st stage G 5/8" Xstream DURATION	002-12	1st stage G 5/8" Xstream DURATION (4+1)
4780-WE	1st stage G 5/8" Xstream DECO	002-15	1st stage G 5/8" Xstream DECO (4+1)
4884-GN	1st stage Xstream DURATION EN 144-3		
4884-WE	1st stage Xstream DECO EN 144-3		

Item #	Description
0012-028	O-ring (Deep)
0011-037	O-ring, viton (Deco/Duration)
4807-59	O-ring, viton (***)
4571	Conn. stem 1.stage Xstream
4871	Conn. stem 1.stage Xstream (**)**
4572	Cup type filter Xstream
4581	Stainl. washer 1.stage Xstream
4576-BK	Wheel G5/8" Xstream, black
4576-WE	Wheel G5/8" Xstream, white
4576-GN	Wheel G5/8" Xstream, green
4876-GN	Wheel Xstream, green (*)
4876-WE	Wheel Xstream, white (**)
4774	Housing 1.stage Xstream
4555	Spring for ball Xstream
4556	Ball 1.stage Xstream
0015-059	O-ring (Deep)
0016-036	O-ring, viton (Deco/Duration)
4758	Zytel valve seat Xstream
4760	Valve seat holder Xstream
4764	Valve seat spring Xstream
4777	Lower pin guide Xstream
4563	Pin bushing 1.stage Xstream
0015-012	O-ring
4762	Upper pin guide Xstream
4559	Actuating pin, Xstream
4564	Roll diaphragm 1.stage Xstream
4565	Pressure plate 1.stage Xstream
4763	Adjust. spring 1.stage Xstream
4570-BK	Barrier 1.stage Xstream black
4570-WE	Barrier 1.stage Xstream white
4570-GN	Barrier 1.stage Xstream green
4767-BK	Cover Xstream 1st stage, black
4767-CE	Cover Xstream 1st stage, chrome
4568	Screw cover M3x10 Xstream, 3 pcs
4798-BK	Adjustment screw, black
4798-CE	Adjustment screw, chrome
2680	Blindscrew UNF7/16
0012-132	O-ring (Deep/Dive)
0011-277	O-ring, viton (Deco/Duration)
2679	Blindscrew UNF3/8, 2 pcs
0010-353	O-ring (Deep/Dive)
0013-164	O-ring, EPDM (Deco/Duration)

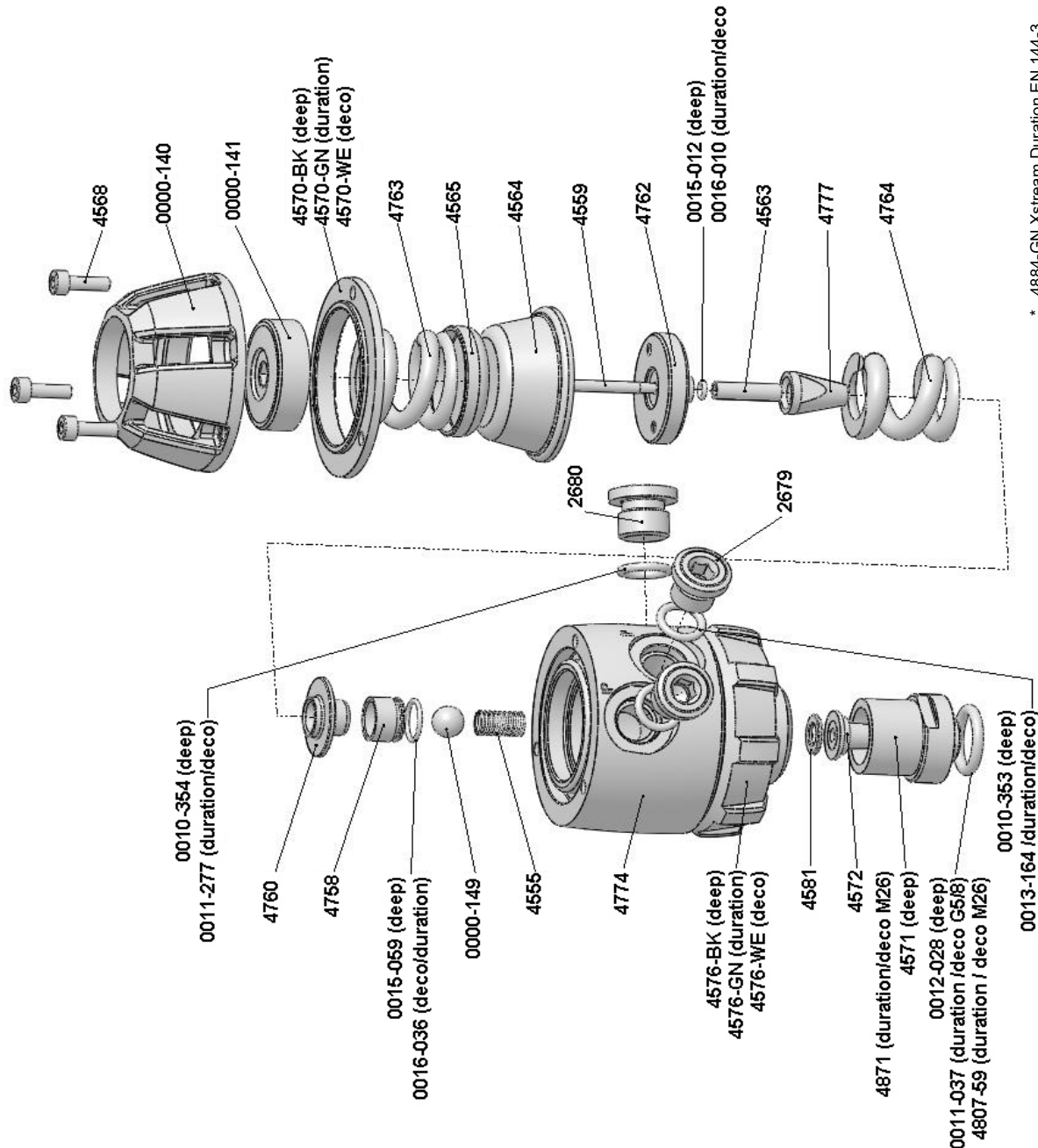

* 4884-GN Xstream Duration EN 144-3
 ** 4884-WE Xstream Deco EN 144-3

First stage 90

4751-BK	1st stage G 5/8" Xstream DEEP90	0110-000	1st stage G 5/8" Xstream Deep90 Mk3
4751-GN	1st stage G 5/8" Xstream DURATION90	0110-003	1st stage G 5/8" Xstream Duration 90 Mk3
4752-BK	1 st stage G 5/8" Xstream DIVE90, DEEP90 (5+2)	0110-001	1st stage M26 Xstream Duration 90 Mk3 EN 144-3
4883-GN	1 st stage Xstream DURATION90 EN 144-3	0110-002	1st stage M26 Xstream Oxygen Mk3 EN 144-3*
001-85	1st stage G 5/8" Xstream DURATION90 (5+2)		* Only sold with MkVI rebreather

Item #	Description
0013-032	O-ring (Deep 90/Dive 90/ Deep 90 EAN40)
0011-037	O-ring, viton (Duration90)
0011-335	O-ring, viton (Duration90 EN 144-3)
4778	Conn. stem 1.stage 90 Xstream
4878	Conn. stem 1.stage Duration90 EN 144-3
4552	Cup type filter long Xstream 90
0012-132	O-ring (Deep90/Dive90)
0011-277	O-ring (Duration90)
4579-BK	Line protector Xstream, black
4579-GN	Line protector Xstream, green
4754	Housing 1.stage 90 Xstream
4754-5IP	Housing 1.stage Dive 90, Deep 90, Duration 90 Xstream (5+2 versions)
4555	Spring for ball Xstream
4556	Ball 1.stage Xstream
0000-149	Ruby ball 1.stage Xstream
0015-059	O-ring (Deep 90/Dive90)
0013-394	O-ring (Deep 90 EAN 40)
0016-036	O-ring, viton (Duration90)
4758	Zytel valve seat Xstream
4760	Valve seat holder Xstream
4764	Valve seat spring Xstream
4777	Lower pin guide Xstream
4563	Pin bushing 1.stage Xstream
0015-021	O-ring
4762	Upper pin guide Xstream
4559	Actuating pin, Xstream
4564	Roll diaphragm 1.stage Xstream
4565	Pressure plate 1.stage Xstream
4763	Adjust. spring 1.stage Xstream
4570-BK	Barrier 1.stage Xstream black
4570-GN	Barrier 1.stage Xstream green
4767-BK	Cover Xstream 1st stage, black
4767-CE	Cover Xstream 1st stage, chrome
4568	Screw cover M3x10 Xstream, 3 pcs
4798-BK	Adjustment screw, black
4798-CE	Adjustment screw, chrome
2680	Blindscrew UNF7/16
0012-132	O-ring (Deep90/Dive90)
0011-277	O-ring, viton (Duration90)
2679	Blindscrew UNF3/8, 3 pcs
0010-363	O-ring (Deep90/Dive90)
0013-164	O-ring, EPDM (Duration90)
4576-BK	Wheel G5/8" Xstream, black
4576-GN	Wheel G5/8" Xstream, green
4876-GN	Wheel Xstream, green (Duration90 EN 144-3)
3726	Valve sealing
3725	Valve piston
1180	Pressure spring
3727	Locking screw

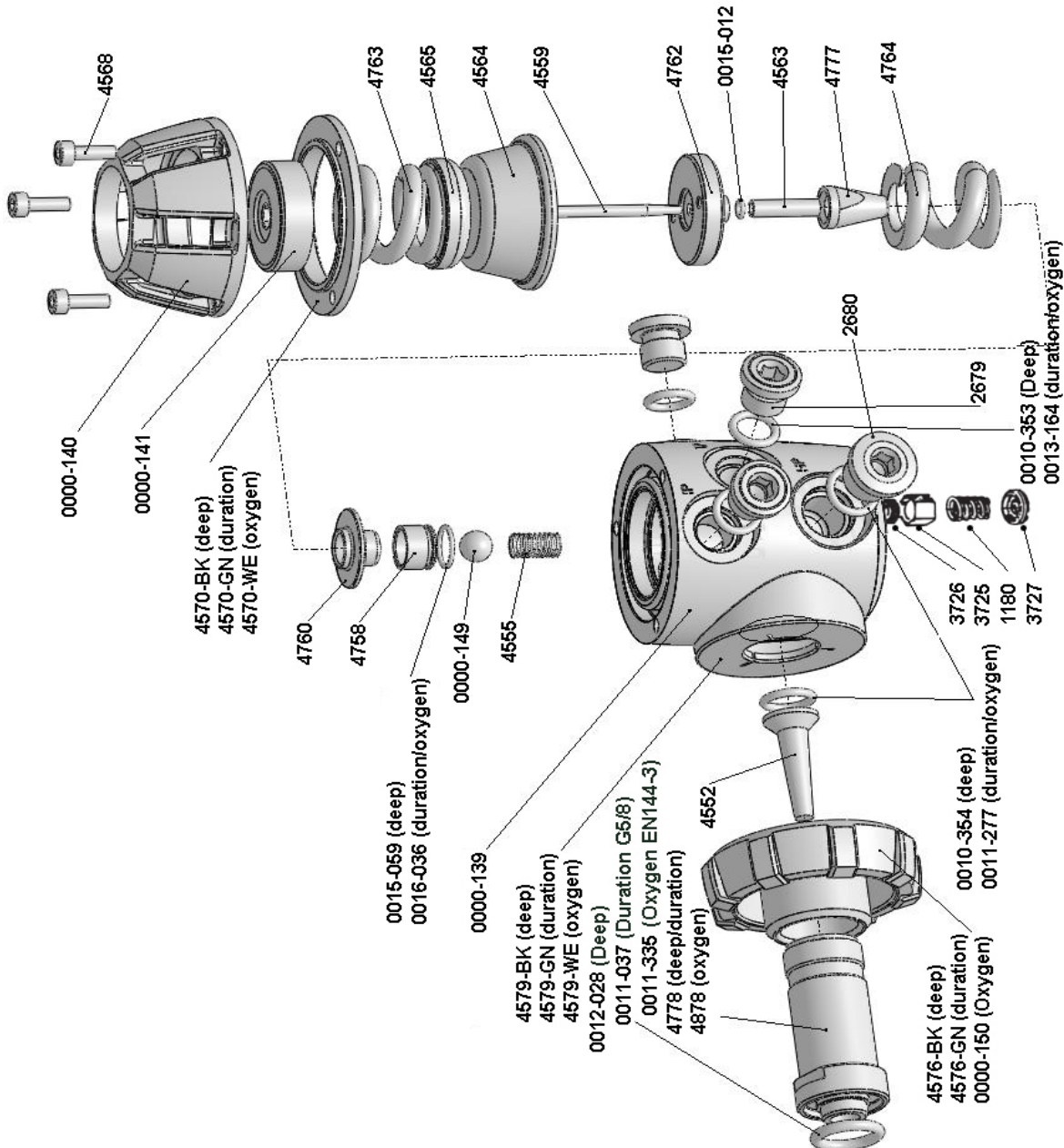

First stage 90 EAN40

0110-000 1st stage G 5/8" Xstream Deep90*

*With serial number 1500001 or higher.

Item #	Description
1	0000-139 - Housing Xstream 90
2	4555 - Ball seat spring
3	0000-149 - Ruby ball
4	0013-394 - O-ring
5	4758 - Ball seat
6	4760 - Seat holder
7	4764 - Seat spring
8	0005-077 - Actuating pin
9	4564 - Rolling diaphragm
10	4570-BK - Barrier, black
11	4565 - Pressure plate
12	4763 - Upper pressure spring
13	0000-091 - 1st stage cover, Xstream
14	4568 - Screw
15	4579-BK - Wheel spacer, black
16	4552 - Filter
17	4576-BK - Connection wheel, black
18	4778 - Connection stem, G5/8"
19	0013-032 - O-ring
20	2679 - Blanking plug, LP
21	0013-164 - O-ring
22	2680 - Blanking plug, HP
23	0013-165 - O-ring
24	3727 - Locking screw, safety valve
25	1180 - Spring
26	3725 - Valve piston
27	3726 - Valve seal

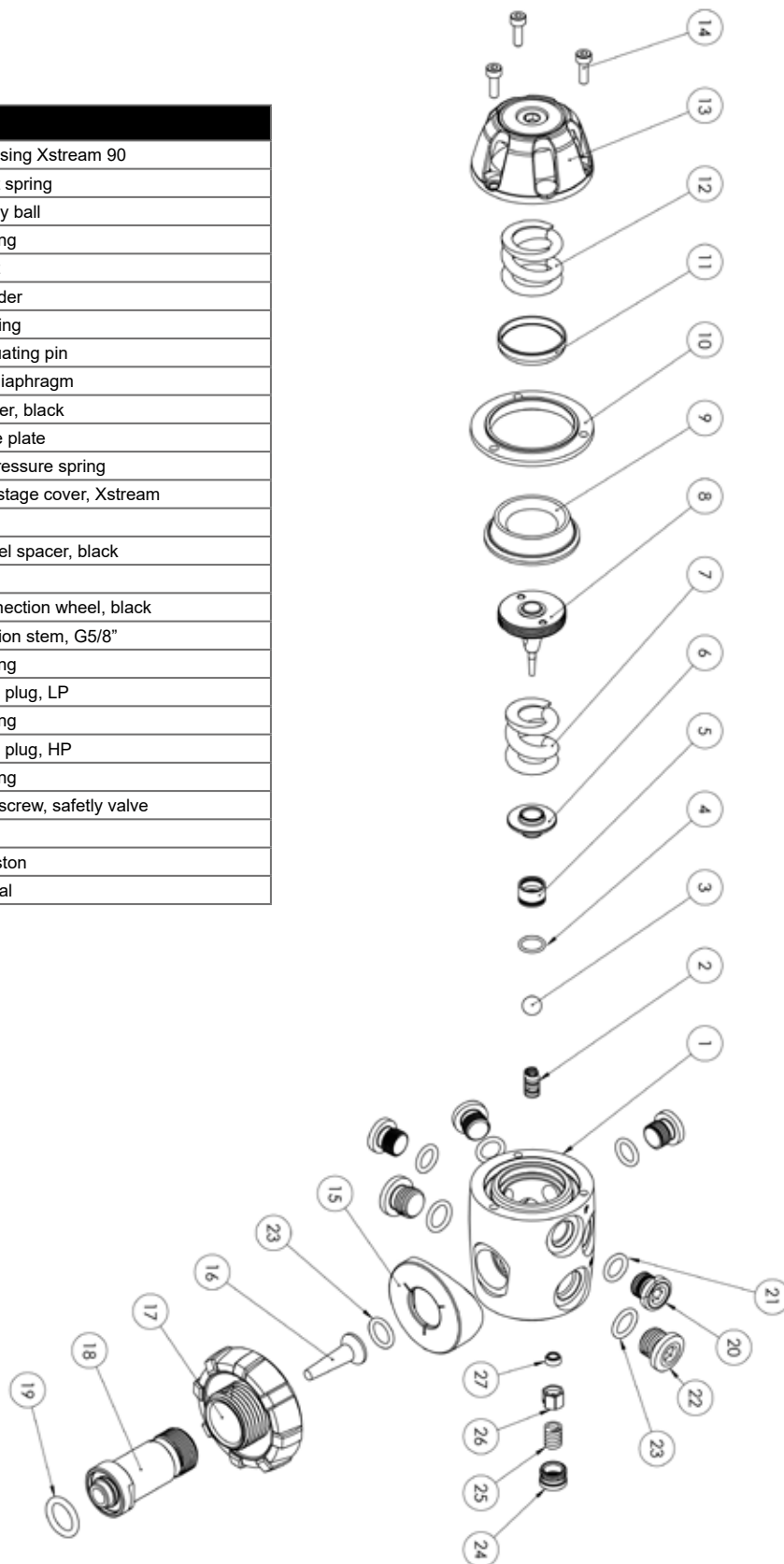

First stage Black

0110-010 1st Stage Xstream Black G5/8**

Item #	Description
1	0002-100 - Housing Xstream 90
2	4555 - Ball seat spring
3	0000-149 - Ruby ball
4	0013-394 - O-ring
5	4758 - Ball seat
6	4760 - Seat holder
7	4764 - Seat spring
8	0005-077 - Actuating pin
9	4564 - Rolling diaphragm
10	4570-BK - Barrier, black
11	4565 - Pressure plate
12	4763 - Upper pressure spring
13	0002-102 - Adjustment screw, Black
14	0002-101 - Cover Xstream 1st stage Black
15	0002-111 - Screw MC6S M3x10, Black
16	4579-BK - Wheel spacer, black
17	0013-165 - O-ring
18	4552 - Filter
19	4576-BK Wheel
20	4778 - Connection Stem G5/8"
21	0013-032 - O-ring
22	0013-164 - O-ring
23	0002-103 - Blanking plug LP, Black
24	0002-104 - Blanking plug HP, Black
25	0002-105 - Locking screw safety valve, black
26	1180 - Spring
27	3725 - Valve piston
28	3726 - Valve seal

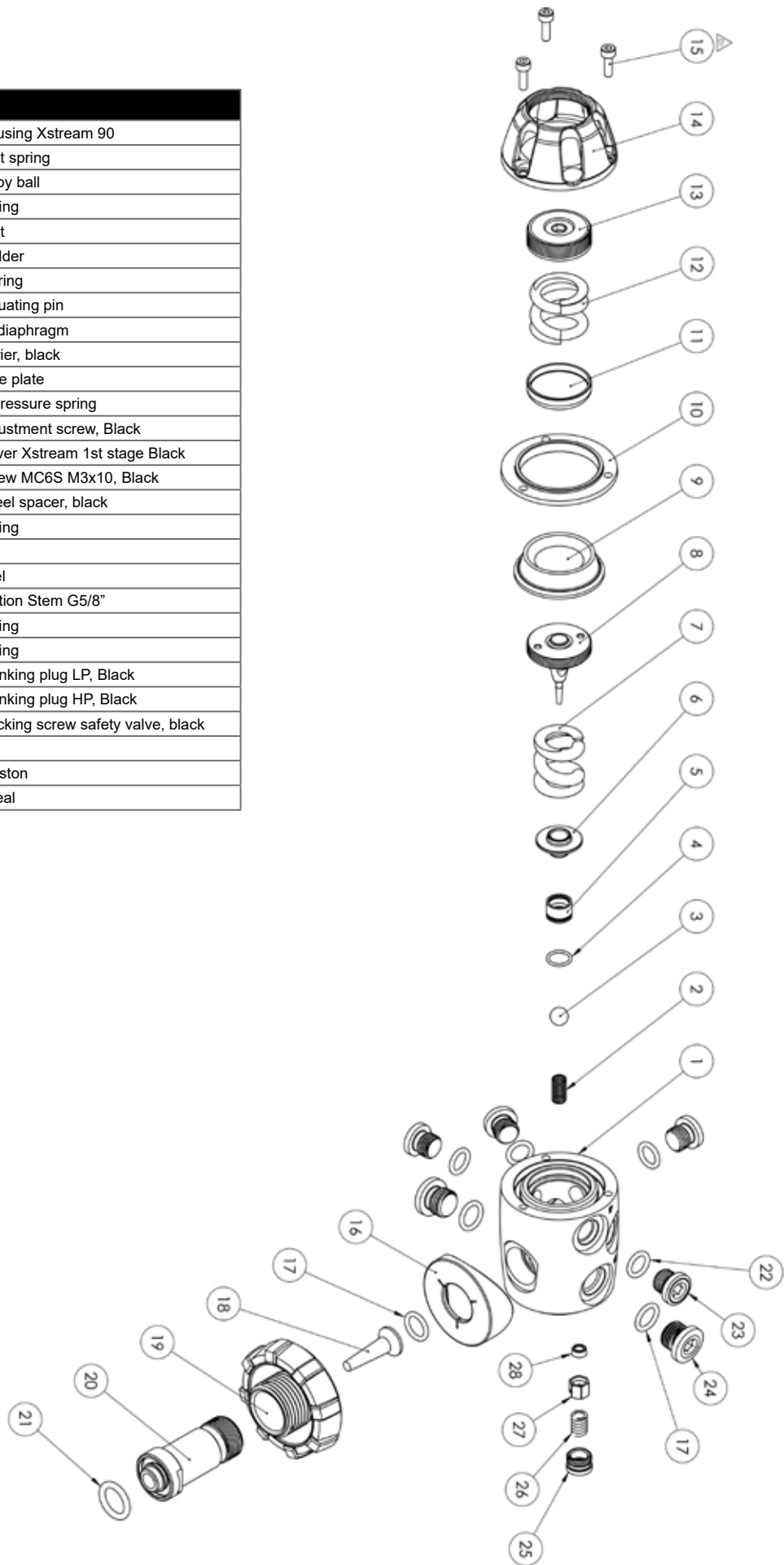

First stage Yoke

0110-020 1st Stage Xstream Deep Yoke

Item #	Description
1	0000-140 Cover Xstream 1st stage
2	0000-141 Adjustment screw
3	0000-139 Valve house 1st stage Xstream, chrome
4	0000-149 Ruby ball
5	0013-164 O-ring
6	0013-165 O-ring
7	0013-394 O-ring
8	1180 Spring
9	2277 Yoke cover
10	2679 Blanking plug LP
11	2680 Blanking plug HP
12	3725 Valve piston
13	3726 Valve sealing
14	3727 Locking screw OPV
15	4555 Ball spring
16	4564 Roll diaphragm
17	4565 Pressure plate
18	4568 Screw M3x10 Xstream
19	4570-BK Barrier black
20	4758 Seat, Xstream
21	4760 Seat holder
22	4763 Spring Xstream upper
23	4764 Spring Xstream centre
24	4559 Actuating pin
25	4563 Bushing
26	0013-392 O-ring
27	4762 Upper Centre Piece, Xstream
28	4777 Lower pin guide
29	3473 A-clamp, Yoke
30	0002-387 Connection, Yoke, Xstream
31	1377 Cup filter
32	3096 Locking screw
33	2922 Yoke handle
34	0010-006 O-ring
35	0011-277 O-ring
36	0050-028 Tamper Proof Sticker "Calibrated"

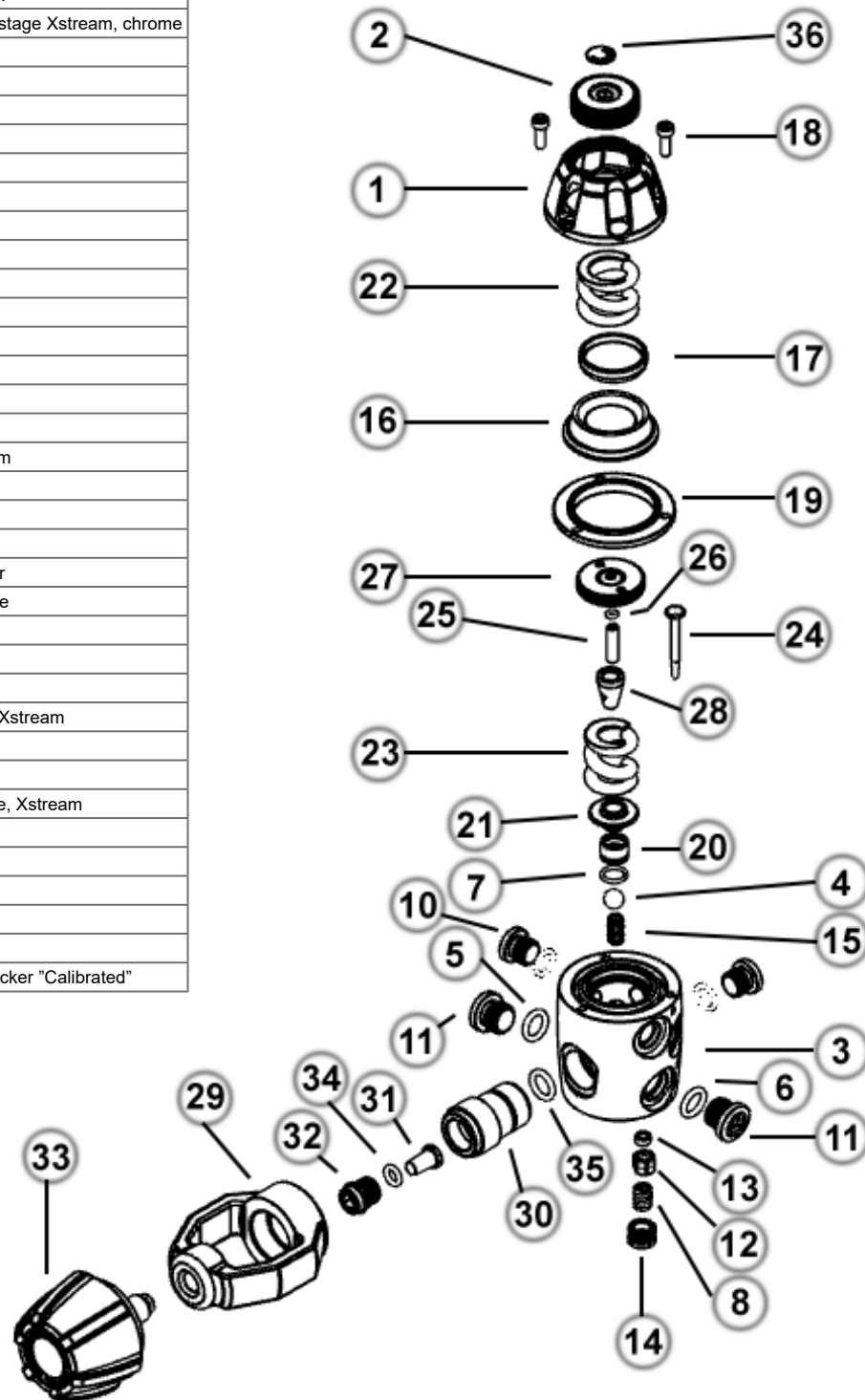

Servicekits

4821 Servicekit Xstream Deep 1:st stage			
Included:	4758	Zytel valve seat Xstream	1 pc
	4572	Cup type filter Xstream	1 pc
	0010-353 (2782)	O-ring (Deep/Dive)	3 pcs
	0010-354 (2918)	O-ring (Deep/Dive)	2 pcs
	0015-059 (4557)	O-ring (Deep/Dive)	1 pc
	0015-012 (4423)	O-ring	1 pc
	0012-028 (1007)	O-ring (Deep/Dive)	1 pc

4822 Servicekit Xstream Deep90, Dive90 1:st stage			
Included	4758	Zytel valve seat Xstream	1 pc
	4552	Cup type filter long Xstream 90	1 pc
	0010-353 (2782)	O-ring (Deep/Dive)	5 pcs
	0010-354 (2918)	O-ring (Deep/Dive)	3 pcs
	0015-059 (4557)	O-ring (Deep/Dive)	1 pc
	0015-012 (4423)	O-ring	1 pc
	3726	Valve sealing	1 pc
	0012-028 (1007)	O-ring (Deep/Dive)	1 pc

4823 Servicekit Xstream Duration, Deco 1:st stage			
Included:	4758	Zytel valve seat Xstream	1 pc
	4572	Cup type filter Xstream	1 pc
	0013-164 (2782-55)	O-ring, EPDM (Deco/Duration)	3 pcs
	0011-277 (2918-59)	O-ring, viton (Deco/Duration)	2 pcs
	0016-036 (4557-59)	O-ring, viton (Deco/Duration)	1 pc
	0015-012 (4423)	O-ring	1 pc
	0011-037 (1007-59)	O-ring, viton (Deco/Duration)	1 pc

4824 Servicekit Xstream Duration90 1:st stage			
Included:	4758	Zytel valve seat Xstream	1 pc
	4552	Cup type filter long Xstream 90	1 pc
	0013-164 (2782-55)	O-ring, EPDM (Deco/Duration)	5 pcs
	0011-277 (2918-59)	O-ring, viton (Deco/Duration)	2 pcs
	0016-036 (4557-59)	O-ring, viton (Deco/Duration)	1 pc
	0015-012 (4423 59)	O-ring	1 pc
	3726	Valve sealing	1 pc
	0011-037 (1007-59)	O-ring, viton (Deco/Duration)	1 pc

4828 Servicekit Xstream Duration90 / Oxygen EN 144-3 1:st stage			
Included:	4758	Zytel valve seat Xstream	1 pc
	4552	Cup type filter long Xstream 90	1 pc
	0013-164 (2782-55)	O-ring, EPDM (Deco/Duration)	5 pcs
	0011-277 (2918-59)	O-ring, viton (Deco/Duration)	3 pcs
	0016-036 (4557-59)	O-ring, viton (Deco/Duration)	1 pc
	0015-012 (4423)	O-ring	1 pc
	3726	Valve sealing	1 pc
	0011-355	O-ring, viton EN 144-3	1 pc

4825 Servicekit Xstream 2nd stage EAN40			
Included:	1167	Locking strap	1 pc
	2787	Rubber plate	1 pc
	0010-025 (1145)	O-ring	1 pc
	0013-009 (1233-55)	O-ring 2nd stage Xstream, EPDM	1 pc
	0011-278 (2856-59)	O-ring Xstream 2nd st., viton	1 pc
	0013-351 (2876-55)	O-ring Xstream 2nd st, EPDM	1 pc
	0013-001 (1896-55)	O-ring Xstream 2nd st , EPDM	1 pc

482N Servicekit Xstream Deep Yoke 1:st stage			
Included	4758	Zytel valve seat Xstream	1 pc
	1377	Cup type filter	1 pc
	0010-353 (2782)	O-ring	5 pcs
	0010-354 (2918)	O-ring	3 pcs
	0015-059 (4557)	O-ring	1 pc
	0015-012 (4423)	O-ring	1 pc
	3726	Valve sealing	1 pc
	0010-006 (1007)	O-ring Yoke	1 pc

Upgrade kits

Xstream Upgrade Kit

4826 Xstream upgrade kit for models below s/n 310001			
Included:	4760	Valve seat holder Xstream	1 pc
	4777	Lower pin guide Xstream	1 pc
	4762	Upper pin guide Xstream	1 pc
	4581	Stainl. washer 1.stage Xstream	1 pc
	0015-012 (4423)	O-ring	1 pc
	4563	Pin bushing 1st stage Xstream	1 pc
Note:	Servicing a Xstream 90 model leaves you 1 pcs washer 4581.		

4767-KIT Xstream adjustment kit for Xstream 1st stages with no adjustmentscrew			
Included:	0000-140	Xstream 1st stage cover	1 pc
	000-141	Adjustment screw	1 pc
	4763	Adjustment spring	1 pc
	4764	Seat spring	1 pc
Note:	Fits all Xstream 1st stages		

Xstream EN 144-3 upgrade kits

4851-GN Xstream Duration90 EN 14-3 kit			
Included:	4878	Connection stem Xstream Duration90 EN 144-3	1 pc
	0003-214	O-ring EN 144-3	1 pc
	0000-151	Wheel Xstream Duration EN 144-3	1 pc
	4552	Cup type filter long Xstream 90	1 pc
	0011-277 (2918-59)	O-ring	1 pc

O-ring conversion table

Old article number	New article number	Note
1007	0012-028	
1007 59	0011-037	
1145	0010-025	
1145 55	0013-018	
1156	0010-009	
1156 59	0011-006	
1164	0010-347	
1233	0012-007	
1233 55	0013-009	
1365	0010-177	
1368	0012-126	
1368 59	0011-270	
1561	0010-352	
1561 59	0011-275	
1562	0010-010	
1562 59	0011-007	
1651	0010-186	
1839	0010-013	
1839 59	0011-009	
1850	0010-343	
1851	0010-018	
1860	0010-112	
1860 59	0011-084	
1861	0015-627	
1861 59	0016-382	
1896	0010-002	
1896 55	0013-001	
2620	0010-122	
2640	0016-019	
2656	0010-006	
2656 59	0011-003	
2782	0010-353	
2782 55	0013-164	
2782 59	0011-276	
2809	0010-015	
2809 59	0011-011	
2856	0010-355	
2856 55	0013-166	
2856 59	0011-278	
2876	0015-019	
2876 55	0013-351	
2877	0015-104	
2918	0012-132	
2918 55	0013-165	
2918 59	0011-277	
3178	0010-054	
3396	0010-011	
3413	0010-358	
3458	0012-009	
3611	0015-157	
3728	0010-028	
3728 59	0011-023	
3734	0010-361	
3779	0015-004	
3779 59	0016-004	
2839	0013-159	
3831	0013-030	
4421 59	0016-085	
4423	0015-012	
4423 55	0013-392	
4423 59	0016-010	
4557	0015-059	
4557 59	0016-036	
4959-0-NR-7	0015-243	

6. Service

The parts that needs to be replaced during a service are described in the Spare parts & Servicekits section of this handbook. Make sure that you have servicekits for the corresponding model and that you have all special tools required available. The tools required are described in the Tools section of this hand book.

⚠️ For instructions on how to service the regulator follow the instruction below until you reach the "GO TO FINAL INSPECTION" text at the end of the instruction. The instructions in this handbook must be followed in detail step by step. Negligence can cause serious injury or even death.

A service includes the following 5 steps:







1. Complete disassembly of the first stage and second.
2. Inspection of disassembled parts.
3. Cleaning prior to assembly.
4. Assembly.
5. Final inspection and adjustment, please refer to section 7 of this handbook.





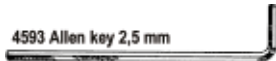





Disassembly

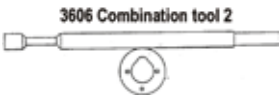

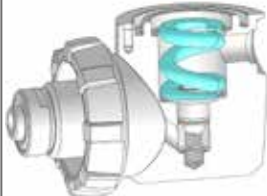









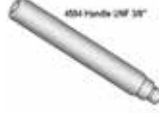

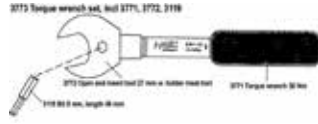

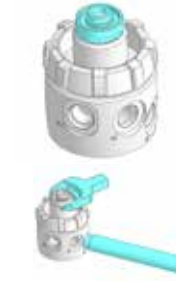
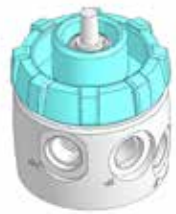
⚠️ Do not disassemble the regulator in the clean room environment. All parts shall be taken to the clean room environment after inspection and after the pre-cleaning process if such is needed. Otherwise you risk to contaminate the clean room environment. New parts should be stored in it's original packing until it is time for assembly.





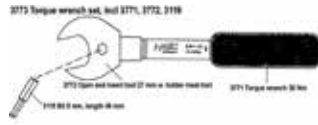

⚠️ To remove o-rings, ONLY use o-ring remover tool 2297. Make sure not to damage o-ring and sealing surfaces!!

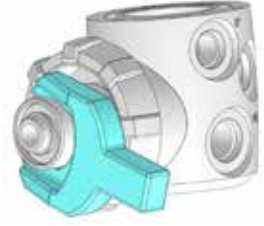
Xstream first stage

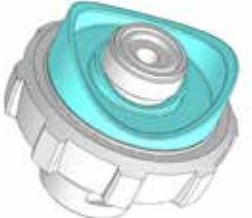

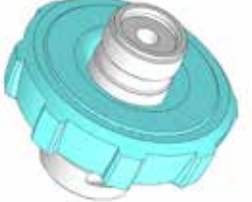

Step	Parts	Tools/Instructions	Replace	Picture
All first stages				
1	2680 Blindscrew UNF 7/16" 1 or 2 pcs 2679 Blindscrew UNF 3/8" 2, 3 or 5 pcs			
2	4568 Screw M3x10 Xstream 3 pcs			
3	4767-BK Cover Xstream first stage black (discontinued) 0000-140 Cover Xstream first stage chrome			
4	4763 Press. spring 1.stage Xstream			





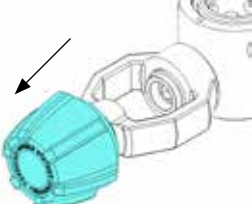

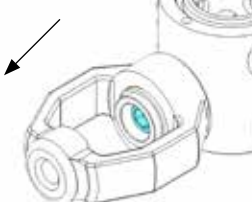
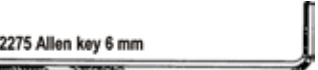
Step	Parts	Tools/Instructions	Replace	Picture
5	4565 Pressure plate 1.stage Xstream			
6	4570-BK Barrier 1.stage Xstream black 4570-WE Barrier 1.stage Xstream white 4570-GN Barrier 1.stage Xstream green			
7	4564 Roll. diaphragm 1.stage Xstream	Only use fingers. Tools may puncture the diaphragm		
8	Pin guide assembly	 3606 Combination tool 2		
9	4764 Valve seat spring Xstream			
10a	4760 Valve seat holder Xstream 4758 Zytel valve seat Xstream	 2297 O-ring remover		
10b	4760 Valve seat holder Xstream 4758 Zytel valve seat Xstream			
10c	4760 Valve seat holder Xstream 4758 Zytel valve seat Xstream	 1246 Allen key 5 mm		



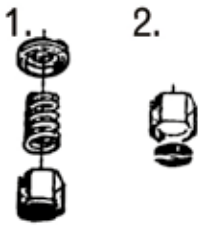

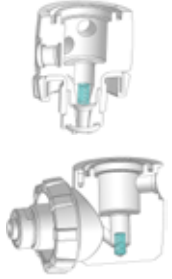

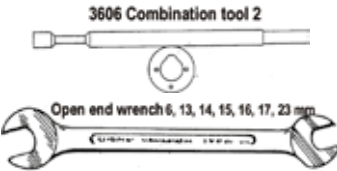
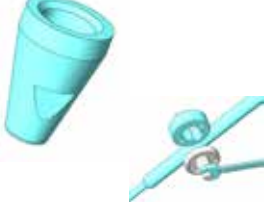
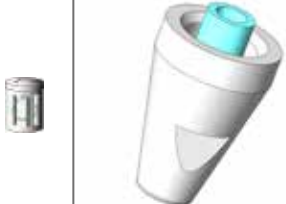

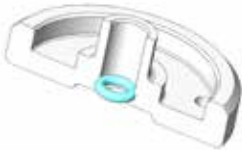
Only for Xstream bottom mounted first stages				
Step	Parts	Tools/Instructions	Replace	Picture
11	0012-028 O-ring (Deep) 0011-037 O-ring, viton (Deco/Duration) 0003-214 O-ring, viton EN 144-3 (Deco EN 144-3/Duration EN 144-3)			
12	4571 Conn. stem 1.stage Xstream	   		
13	4576-BK Wheel G5/8" Xstream, black 4576-WE Wheel G5/8" Xstream, white 4576-GN Wheel G5/8" Xstream, green 0000-151 Wheel Xstream Duration M26, green 0000-150 Wheel Xstream Deco M26, white			
14	4572 Cup type filter Xstream			
15	4581 Stainl. washer 1.stage Xstream			
Only for Xstream 90 first stages				
16	0013-032 O-ring (Deep90 EAN40) 0012-028 O-ring (Deep90/Dive90) 0012-028 59 O-ring viton (Duration90) 0003-214 O-ring, viton EN 144-3 (Duration90 / Oxygen M26)			
17	4778 Conn. stem 1.stage 90 Xstream 4878 Conn. stem 1.stage EN 144-3 (Duration90 M26)	  		

18	4576-BK Line protector Xstream, black 4576-GN Line protector Xstream, green			
19	0013-165 O-ring (Deep90 EAN40) 0012-132 O-ring (Deep90/Dive90) 0011-277 O-ring Viton (Duration90/Oxygen)			
20	4576-BK Wheel G5/8" Xstream, black 4576-GN Wheel G5/8" Xstream, green 0000-151 Wheel Xstream Duration M26, green 0000-150 Wheel Xstream Deco M26, white			
21	4552 Cup type filter long Xstream 90			

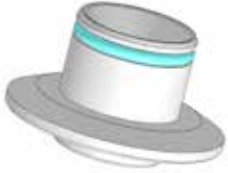
Only for Xstream Yoke 1st stages

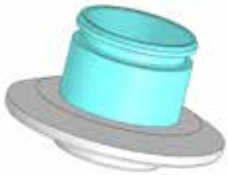

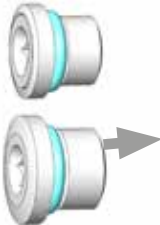

18Y	2922 Yoke handle	Unscrew the yoke handle		
19Y	3096 Locking screw 1377 cup filter 0010-006 O-ring	Unscrew the Locking screw and remove it along with the cupfilter and o-ring. 		
20Y	0002-386 Yoke clamp Xstream 0002-387 Connection stem Yoke, Xstream 0011-277 O-ring	Remove the yoke clamp by inserting a 6 mm Allen key in to the center of the yoke connection stem and unscrewing the stem 		







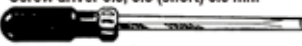
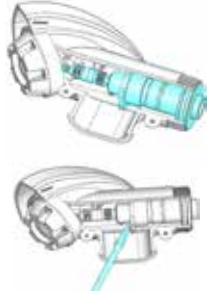



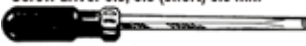



<p>21</p>	<p>Over pressure valve (only 1st stages with a built in OP valve)</p> <p>3726 Valve sealing 3725 Valve piston 1180 Pressure spring 3727 Locking screw</p>	<p>1. Remove the locking screw with a 4mm Allen wrench. Remove the pressure spring and the valve piston.</p> <p>2. Remove the valve sealing from the valve piston with an o-ring remover.</p>	
<p>All first stages</p>			
<p>22</p>	<p>4556 Ball 1.stage Xstream 0000-149 Ruby ball, Xstream</p> 		
<p>23</p>	<p>4555 Spring for ball Xstream</p>		
<p>24</p>	<p>4559 Actuating pin, Xstream</p>		
<p>25</p>	<p>4777 Lower pin guide Xstream</p>	 <p>6 mm</p>	
<p>26</p>	<p>4563 Pin bushing 1.stage Xstream</p> <p>Do not pull out nor replace the Pin bushing while servicing Dive or Deep models. This should only be done while servicing Deco, Oxygen and Duration models.</p>	<p>Screw in M3 screw 4568 in the pin bushing and pull out.</p>	
<p>27</p>	<p>0013-392 O-ring (EAN40) 0015-012 O-ring</p>		

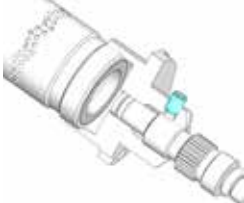







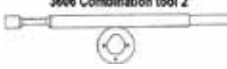
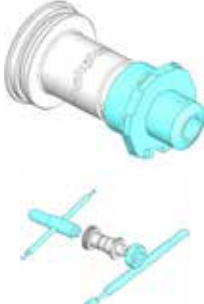



28	0013-394 O-ring (Deep90 EAN 40) 0015-059 O-ring (Deep/Dive) 0016-036 O-ring, viton (Deco/Duration)	2297 O-ring remover 		
29	4758 Zytel valve seat Xstream			
30	On blindscrew UNF 3/8" 0010-353 O-ring Deep 2 or 3 pcs, Dive 5 pcs 0013-164 O-ring Deep 90 EAN40, 4 pcs 0013-064 O-ring EPDM Deco 2 or 3 pcs Duration 2 or 3 pcs On blindscrew UNF 7/16" 0012-132 O-ring Deep 1 pcs, Dive 2 pcs 0013-165 O-ring Deep90 EAN40, 2 pcs 0012-132 59 O-ring Viton Deco/Duration 1 pcs	2297 O-ring remover 		
31	0000-141 Adjusting screw Chrome	1246 Allen key 5 mm 		

Xstream second stage

⚠ To remove o-rings, ONLY use o-ring remover tool 2297. Make sure not to damage o-ring surfaces!! Do not disassemble the exhalation check-valve, since this is not included in the servicing kit and can be hard to put back if taken out.

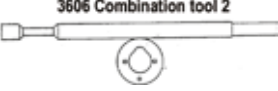
Step	Parts	Tools	Replace	Picture
1	4532 Mouthpiece AIR	Pliers  For cutting strap		
2		Screw driver 3.5, 5.5 (short) 8.5 mm 		
3	4538-BK Cover Xstream 2nd stage (Deep) 4538-WE Cover Xstream 2nd stage (Deco) 4538-GN Cover Xstream 2nd stage (Duration) 4538-YW Cover Xstream 2nd stage (Octopus)	Twist off.		

4	4536 Diaphragm cover	 Snap connection.		
5	4533 Diaphragm silicone			
6	4531 Checkvalve	<p>Do not remove! Unless damaged</p>		
7	4545 Servo-valve Xstream			
8	2875 Stop screw			
9	4534 Valve tube Xstream			
10	0013-001 O-ring 2nd stage Xstream, EPDM			
11	0013-365 O-ring 2nd stage Xstream, EPDM			
12	4547 Valve housing nut, Xstream	 		

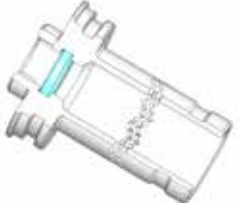
13	2787 Rubber plate			
14	0013-009 O-ring 2nd stage Xstream, EPDM			
15	0010-025 O-ring			
16	3440 Valve insert			
17	0011-278 O-ring Xstream 2nd st., viton			

Inspections

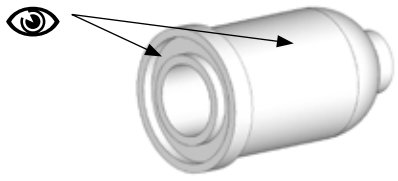
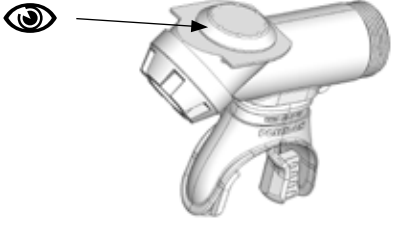
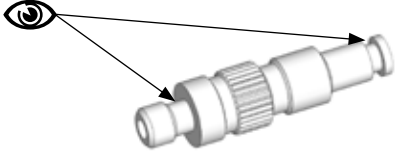
Step	Parts	Inspect	Picture
1	3440 Valve insert	1. Ensure no circular cuts on bladder surface. 2. Check O-ring sealing surface	
2	4531 Checkvalve	1. Check for damages on check valve edge	
3	4534 Valve tube Xstream	1. Check O-ring sealing surfaces	

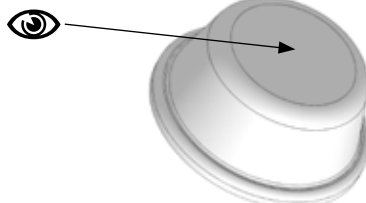
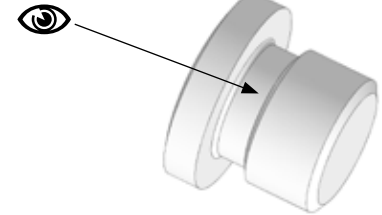
4	4545 Servo-valve Xstream	1. Make sure not bent	
5	4754 Housing 1.stage 90 Xstream	1. Check sealing surfaces	
6	4774 Housing 1.stage Xstream	1. Check sealing surfaces	
7	4564 Roll.diaphragm 1.stage Xstream	1. Check for wear and tear	
Step	Parts	Inspect	Picture
8	2680 Blindscrew UNF7/16 2679 Blindscrew UNF3/8,	1. Check O-ring sealing surfaces	
9	4571 Conn. stem 1.stage Xstream 4871 Conn. stem 1.stage Xstream EN 144-3 (Deco EN 144-3/Duration EN 144-3)	1. Check O-ring sealing surfaces	
10	4778 Conn. stem 1.stage 90 Xstream 4878 Conn. stem 1.stage Xstream EN 144-3 (Duration90 EN 144-3)	1. Check O-ring sealing surfaces	

Cleaning

Xstream Deep/Dive/Deep EAN40 Cleaning



Make absolutely sure Hydrochloric acid is NOT poured into the ultra-sonic cleaner. It would then destroy the ultra-sonic cleaner and the parts attempted to be cleaned.

If corrosion or salt deposits occurs on metallic parts, immerse part in concentrated Hempodid* or 15% Hydrochloric acid for about 10 minutes or clean them using an ultra sonic cleaner. Then rinse them thoroughly in fresh water and blow them dry with air. The synthetic parts must not be treated with solvents and must only be cleaned with fresh water.

*Hempodid=Acid Liquid detergent containing phosphoric acid (5-10%) and bactericide for disinfectant cleaning

Xstream Deep EAN40

Xstream Deep EAN40 1st stages/regulators intended to be used with Nitrox/Enriched gas up to EAN40 should always be cleaned using an ultra sonic cleaner. Avoid touching the cleaned components with your bare hand, use latex or lint free gloves when handling the components.

When cleaned rinse them thoroughly in fresh water and blow them dry with air.

Store components in such a way that they don't risk getting in contact with silicone based lubricant.

0000-149 Ruby Ball Xstream

Ultrasonic washing does not damage this ruby ball but you need to insure the balls are separated so that they do not touch or have contact with each other. We suggest to use a fixture in the ultrasonic wash to separate them from each other.

Xstream Deco/Duration Cleaning for Oxygen Use

The process of cleaning for oxygen use and the information given herein shall be strictly adhered to. Only then can Poseidon guarantee the regulator will be cleaned to a cleanliness level which is acceptable for its intended use. This process has been verified to produce hydrocarbon residual levels less than 50mg/m² and a particulate level less than Cleaning Test Level 100 (ASTM G 93 Spec.)

As an alternative, oxygen servicing procedures can be carried out in accordance with other herein listed organizations standard procedures and requirements. However, the use of cleaning agents, the order of the operating sequences and the time to treat parts during ultra sonic cleaning as specified in this manual must be adhered to. Wherever there is a conflict between the procedures and set of requirements, unless the other procedure represents a greater requirement for cleanliness, this manual takes precedence. Some methods, equipment, and detergents which are not mentioned in this manual can have a harmful or unknown effect on materials, such as e.g. ozone cleaning systems, strong acids etc. and shall therefore be discarded.

The other standard procedures that can be used given the limitations above are:

EAN and Oxygen Servicing Procedures, Fourth Edition (ANDI)

IANTD Gas Blender & Service Technician Program, First Edition, August 1999

MIL-STD-1330D (SH) of the 20 September 1996



The safety of your customer and yourself depends on you carefully and strictly following these instructions. Negligence in any step can cause serious injury or even death.



You must be certified by Poseidon as oxygen technician to undertake this procedure.



Keep hands and tools clean and free from grease, except for what is required and stated in this manual.



Use protective clothing to prevent dust, fingerprints, hair, and particles to contaminate.



Use only dedicated and cleaned tools.



Ensure your oxygen handling is in conjunction with national laws.



Ensure no foreign contaminants, such as e.g. liquids, grease, particulate, dust, and mist can enter into the cleanroom area.

The cleanroom area and work environment requirements

The cleanroom area and work environment should be setup according to minimum demands listed in Appendix D. A cleanroom area and work environment audit should be performed once a year either by a service technician or by a from Poseidon appointed auditor. The checklist in Appendix D should be used to make sure that all criterias are fulfilled. For detailed instructions on how to perform and audit please refer to Appendix D.

Preparations and Pre-cleaning

1. These preparations and the pre-cleaning shall NOT be conducted in the clean room, since it may then contaminate the clean room.
2. If any part is visibly contaminated, it shall be pre-cleaned, including the parts listed below which shall not be ultra sonic cleaned.
3. Only undertake the pre-cleaning if you are sure you can move on to the cleaning stage immediately after. If the parts dry between the two stages of operation, undesirable deposits can be left on part surfaces.
4. Bag the parts below in a plastic bag for later assembly. These parts shall not be ultra sonic cleaned.



5. Use IPA and a toothbrush to agitate away all visible contaminants. Rinse part(s) in municipal running water until all visible soil, particulate and cleaning agent is removed. When using IPA make sure you have sufficient ventilation. Please refer to the safety instructions of the IPA.
6. Use air of any quality to blow dry.

THE PROCESS BELOW SHOULD BE PERFORMED OUTSIDE THE CLEANROOM AREA**Cleaning**

1. Wash your hands before this cleaning process.
2. Always ensure the UltraSonic cleaner is absolutely clean inside
3. Fill the UltraSonic cleaner with Poseidon FineClean Ultra and water in the ratio 1:5.
4. Let the UltraSonic cleaner reach its working temperature 60-70°C .
5. Place all parts in the basket. The parts shall be placed so that no air is trapped inside. Turn the part a few times under the solution until no bubbles are coming from it. Ultra Sonic cleaning agitates away contaminants, why it is important to finally place the part so that contaminants can drop out freely, i.e. open holes pointing down. (as shown in the figure). Ensure parts are not contacting each other, since that may reduce the cleaning effectiveness.
6. Immerse and ultra sonic clean the parts for 20-25 minutes
7. 3440, rolling diaphragm and the servovalve shall only be cleaned for 10 minutes
8. Bring all parts needed to assemble the complete regulator to the clean room. Keep the bagged 2nd stage parts and the service kit parts in their bags until immediately before assembly.

THE PROCESS BELOW SHOULD BE PERFORMED INSIDE THE CLEANROOM AREA**Rinsing and drying in the cleanroom**

From this stage and through the assembly stages cleanroom clothing including gloves shall be used.

Pick up each part from the basket and rinse carefully under running water at least 30 seconds per part, or; Rinse in two stages keeping the parts in the basket. Immerse the basket with the parts in another container of at least 3 litres of clean water and agitate for at least 5 minutes. Then replace the rinsing water with new clean water (ideally deionised, distilled, and filtrated water), and rinse for another 5 minutes. Ensure all cavities are carefully rinsed. It is the internal rinsing which is the most important!

Dry the parts by using a cleaned blowgun and clean air, and blow dry each part carefully.

Verification

White light

All parts shall be observed for the absence of contaminations under strong white light and for the accumulations of lint fibres. This method will detect particulate matter in excess of 50 microns and other contaminations in relatively large amounts. The part being examined must be recleaned if any contamination is detected using this method. You shall have access to, and use if found necessary, a magnifying glass or a microscope with at least x10 magnification.

Ultraviolet light (Blacklight)

Examine all parts in darkness using an ultraviolet light of between 3200 to 3800 Angstrom wavelength. If a bluish-white fluorescent blotch, smear, smudge, or film is present, the part must be recleaned. Ultraviolet light inspection will help to verify that cleaned surfaces are free from any hydrocarbon fluorescence.





If parts cannot be used immediately for assembly, pack in clean plastic bags to avoid parts from being recontaminated.





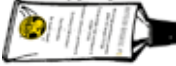
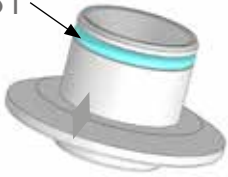

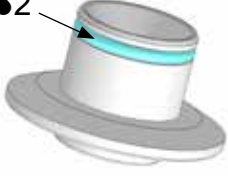
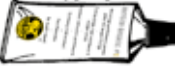
Assembly



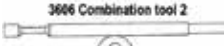
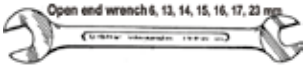

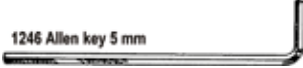
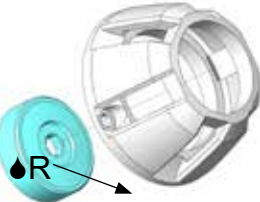
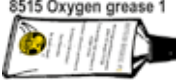
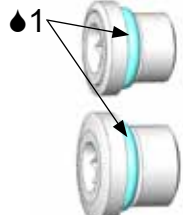

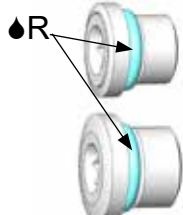

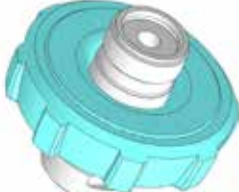
⚠ Lubricants shall be used sparingly. Excessive quantities of lubricant can trap particulate and other contaminants developing a potential fire hazard.

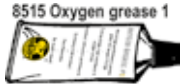



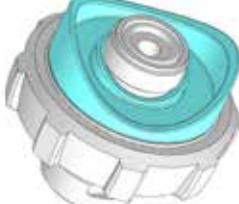
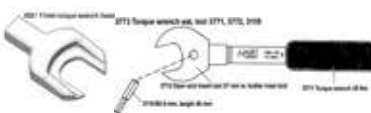
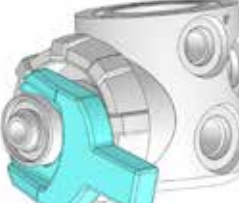
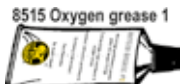
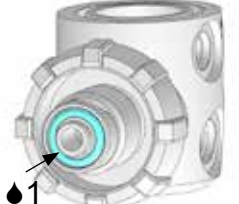



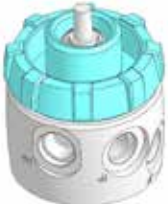
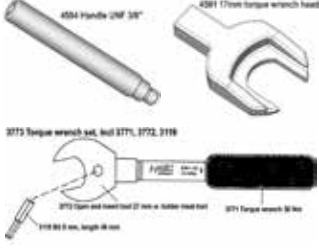

⚠ Parts marked with the () symbol are parts that must be replaced at every service. New parts should be stored in its original packing until it is time for assembly.

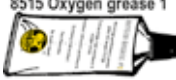
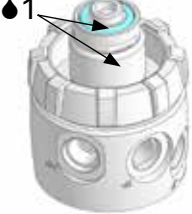

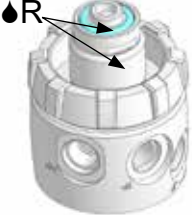
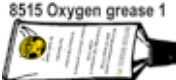
Xstream first stage

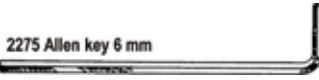

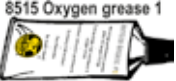



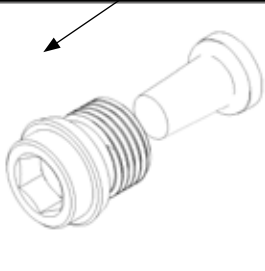
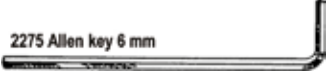
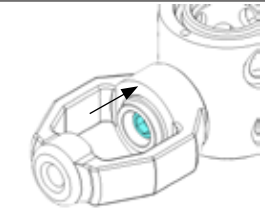
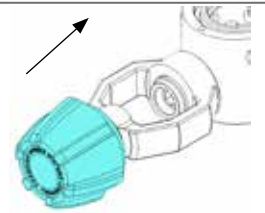

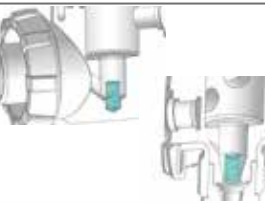
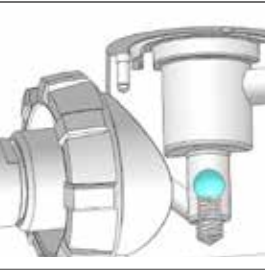
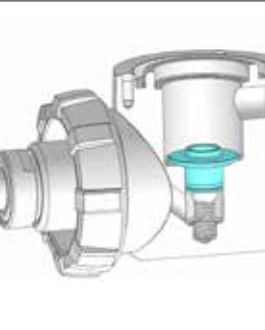

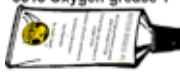
Step	Parts	Tools/Instructions	Replace	Picture
All first stages				
1	4758 Zytel valve seat Xstream		()	
2a	0016-036 O-ring, viton (Deco/Duration) 0013-394 O-ring (Deep EAN40)	Deco/Duration/Oxygen/ Deep EAN40 8515 Oxygen grease 1 	()	
2b	0015-059 O-ring (Deep/Dive)	Deep/Dive 8516 Regulator grease 	()	
3	0015-012 O-ring 0013-392 O-ring (Deep EAN 40)	Use bushing 4563 to install o-ring 8515 Oxygen grease 1 		

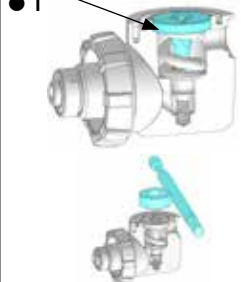



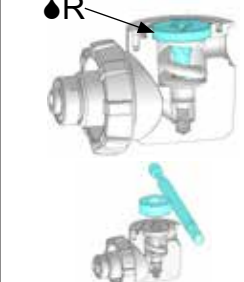

4	4763 Pin bushing 1.stage Xstream	Make sure fully to the bottom		
5	4777 Lower pin guide Xstream	  <p>3 +/- 1 Nm Refer to section 9 for other units.</p>		
6	4759 Actuating pin, Xstream	Lubricate pin at top section only. Leaving lower end dry. Wipe off excessive grease under the hat.		
7	4798 Adjusting screw			
8a	<p>On blindscrew UNF 3/8"</p> <p>0013-164 O-ring Deep 90 EAN40, 4 pcs 0013-064 O-ring EPDM Deco 2 or 3 pcs Duration 2 or 3 pcs</p> <p>On blindscrew UNF 7/16"</p> <p>0013-165 O-ring Deep90 EAN40, 2 pcs 0012-132 59 O-ring Viton Deco/Duration 1 pcs</p>	<p>Deco/Duration/Oxygen/Deep EAN40</p> 	<p>()</p>	
8b	<p>On blindscrew UNF 3/8"</p> <p>0010-353 O-ring Deep 2 or 3 pcs, Dive 5 pcs</p> <p>On blindscrew UNF 7/16"</p> <p>0012-132 O-ring Deep 1 pcs, Dive 2 pcs</p>	<p>Deep/Dive</p> <p>8516 Regulator grease</p> 	<p>()</p>	
9	4552 Cup type filter long Xstream 90		<p>()</p>	
10	<p>4576-BK Wheel G5/8" Xstream, black 4576-GN Wheel G5/8" Xstream, green 4876-GN Wheel Xstream, green (Duration90 EN144-3)</p>			

11a	0011-277 O-ring Viton (Duration90) 0013-165 O-ring (Deep90 EAN40)	<p>Deco/Duration/Oxygen/ Deep EAN40</p> 	↻	
11b	0012-132 O-ring (Deep90/Dive90)	<p>Deep/Dive</p> 	↻	
12	4576-BK Line protector Xstream, black 4576-GN Line protector Xstream, green			
13	4771 Conn. stem 1.stage 90 Xstream 4878 Conn. stem 1.stage Xstream EN 144-3 (Duration90 EN 144-3)	 <p>Ensure line protector is correctly positioned, with one slot facing to the bottom of the housing Torque setting 30 Nm Refer to section 9 for other units.</p>		
14a	0012-028 59 O-ring viton (Duration90) 0003-214 O-ring viton EN 144-3 (Duration90 EN 144-3) 0013-032 O-ring (Deep90 EAN40)	<p>Deco/Duration/Oxygen/ Deep EAN40</p> 	↻	
14b	0012-028 O-ring viton (Deep/Dive)	<p>Deep/Dive</p> 	↻	
180 degree model				
15	4581 Stainl. washer 1.stage Xstream			
16	4572 Cup type filter Xstream		↻	

17	4572 Cup type filter Xstream		↻	
18	4576-BK Wheel G5/8" Xstream, black 4576-WE Wheel G5/8" Xstream, white 4576-GN Wheel G5/8" Xstream, green 4876-GN Wheel Xstream, green (Duration EN144-3) 4876-WE Wheel Xstream, white (Deco EN144-3)			
19	4571 Conn. stem 1.stage Xstream 4871 Conn. stem 1.stage Xstream EN 144-3 (Duration EN 144-3/Deco EN 144-3)	 <p>Use handle to hold first stage. Torque setting 30 Nm Refer to section 9 for other units.</p>		
20a	0011-037 O-ring, viton (Deco/Duration/Oxygen) 0003-214 O-ring, viton EN 144-3 (Deco M26/Duration M26/Oxygen)	<p>Deco/Duration</p> 	↻	
20b	0012-028 O-ring (Deep/Dive)	<p>Deep</p> 	↻	
Xstream Yoke				
21Y	0011-277 O-ring 0002-387 Connection Yoke	<p>Lubricate o-ring</p> 		
22Y	0011-277 O-ring 0002-387 Connection Yoke 0002-386 Yoke clamp	<p>Mount the yoke connection in to the yoke clamp and use a 6 mm Allen key to screw the conenction in to the 1st stage housing. Torque 30 N +/- 1 N</p> 		
23Y	1377 cup filter 0010-006 O-ring	<p>Mount o-ring #0010-006 on to cup filter 1377. Lubricate o-ring</p> 		

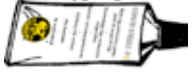
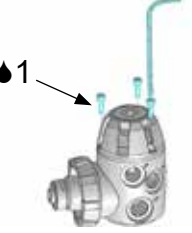
Step	Parts	Tools/Instructions	Replace	Picture
24Y	1377 cup filter 0010-006 O-ring 3096 Locking screw	Place the cupfilter with the mounted o-ring in to the locking screw.		
25Y	1377 cup filter 0010-006 O-ring 3096 Locking screw	Place the locking screw in to the Connection Yoke and screw it in using a 6 mm Allen key. 		
26Y	2922 Yoke handle	Screw the Yoke handle in to the Yoke clamp.		
27	4555 Spring for ball Xstream	 Wider end facing upwards, towards the ball.		
28	0000-149 Ruby Ball Xstream Dia 7mm			
29	4760 Valve seat holder Xstream 4758 Zytel valve seat Xstream			

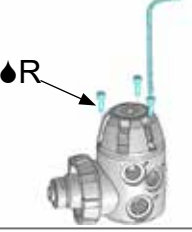
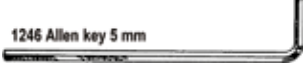









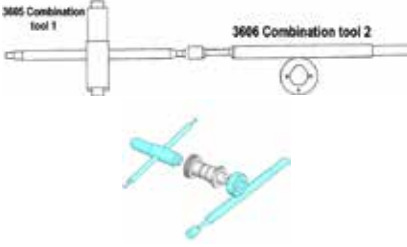

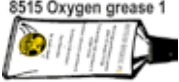
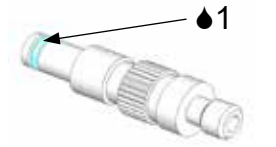
30	4761 Valve seat spring Xstream		
31a	Pin guide assembly	<p>Deco/Duration/Oxygen/Deep EAN40 8515 Oxygen grease 1</p>  <p>3666 Combination tool 2</p>  <p>3 +/- 1 Nm Refer to section 9 for other units.</p>	<p>1</p> 
	<p><u>Over pressure valve assembly</u> (only 1st stages with a built in OP valve)</p> <p>3726 Valve sealing 3725 Valve piston 1180 Pressure spring 3727 Locking screw</p>	<p>1. Attach the new valve sealing to the valve piston and place the valve piston in the OP valve hole with the seal towards the housing.</p> <p>2. Place the pressure spring in the valve piston and tighten the locking screw with a 4 mm Allen key.</p>	
31b	Pin guide assembly	<p>Deep/Dive 8516 Regulator grease</p>  <p>3666 Combination tool 2</p>  <p>3 +/- 1 Nm Refer to section 9 for other units.</p>	<p>R</p> 
32	4564 Roll. diaphragm 1.stage Xstream		
33	<p>4570-BK Barrier 1.stage Xstream black 4570-WE Barrier 1.stage Xstream white 4570-GN Barrier 1.stage Xstream green</p>	<p></p> <p>You should see the marking "This side up" on the barrier.</p>	
34	4565 Pressure plate 1.stage Xstream		

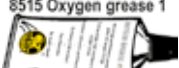



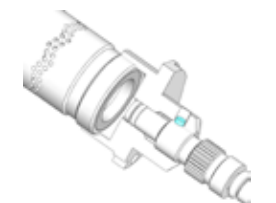

35	4766 Adj. spring 1.stage Xstream		
36	4567-BK Cover Xstream first stage, black 4567-CE Cover Xstream first stage, chrome		
37a	4568 Screw cover M3x10 Xstream 3 pcs	<p>Deco/Duration/Oxygen/Deep EAN40 8515 Oxygen grease 1</p>  <p>4593 Allen key 2,5 mm</p> <p>1 - 2,5 Nm Refer to section 8 for other units.</p>	
37b	4568 Screw cover M3x10 Xstream 3 pcs	<p>Deep/Dive 8516 Regulator grease</p>  <p>4593 Allen key 2,5 mm</p> <p>1 - 2,5 Nm Refer to section 9 for other units.</p>	
38	2680 Blindscrew UNF 7/16" 1 or 2 pcs 2679 Blindscrew UNF 3/8" 2, 3 or 5 pcs	 <p>1246 Allen key 5 mm</p>	

 **Parts marked with the (C) symbol are parts that must be replaced at every service. New parts should be stored in their original packing until it is time for assembly.**

Xstream second stage

Step	Parts	Tools/Instructions	Replace	Picture
1a	0011-278 O-ring Xstream 2nd st., viton	<p>Deco/Duration/Deep EAN40</p>	(↻)	
1b	0011-278 O-ring Xstream 2nd st., viton	<p>Deep/Dive</p>	(↻)	
2	3440 Valve insert			
3a	0010-025 O-ring	<p>Deco/Duration/Deep EAN40</p>	(↻)	
3b	0010-025 O-ring	<p>Deep/Dive</p>	(↻)	
4a	0013-009 O-ring 2nd stage Xstream, EPDM	<p>Deco/Duration/Deep EAN40</p>	(↻)	
4b	0013-009 O-ring 2nd stage Xstream, EPDM	<p>Deep/Dive</p>	(↻)	
Step	Parts	Tools/Instructions	Replace	Picture

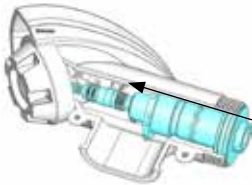
5	4547 Valve housing nut, Xstream	 <p>3605 Combination tool 1 3606 Combination tool 2</p> <p>1 +/- 1 Nm</p>		
6a	0013-365 O-ring 2nd stage Xstream, EPDM	<p>Deco/Duration/Deep EAN40</p>  <p>8515 Oxygen grease 1</p>	⌚	 <p>1</p>
6b	0013-365 O-ring 2nd stage Xstream, EPDM	<p>Deep/Dive</p>  <p>8516 Regulator grease</p>	⌚	 <p>R</p>
7a	0013-001 O-ring 2nd stage Xstream, EPDM	<p>Deco/Duration/Deep EAN40</p>  <p>8515 Oxygen grease 1</p>	⌚	 <p>1</p>
7b	0013-001 O-ring 2nd stage Xstream, EPDM	<p>Deep/Dive</p>  <p>8516 Regulator grease</p>	⌚	 <p>R</p>
8	4534 Valve tube Xstream			
9	2787 Rubber plate	 <p>2297 O-ring remover</p>	⌚	
10	2875 Stop screw	 <p>2706 Allen key 1,5 mm</p>		

Step	Parts	Tools/Instructions	Replace	Picture
11	4545 Servo-valve Xstream	Firm by hand		
12	4531 Exhalation diaphragm	ONLY IF REPLACED		
13	4533 Diaphragm silicone			
14	4536 Diaphragm cover			
15	4538-BK Cover Xstream 2nd stage (Deep) 4538-WE Cover Xstream 2nd stage (Deco) 4538-GN Cover Xstream 2nd stage (Duration) 4538-YW Cover Xstream 2nd stage (Octopus) 4538-GY Cover Xstream 2nd stage (Dive)			
16		Install valve tube		
17	4532 Mouthpiece AIR		↻	

GO TO FINAL INSPECTION

7. Final inspection

Setting, final inspection

Property 1st stage	Setting SI units	Setting common units	Setting US units
Max tank pressure	20 - 30 MPa	200 - 300 bar	2900 - 4351 psi
Empty tank pressure	2 MPa	20 bar	290 psi
IP at max tank pressure	800 – 1100 kPa (unadjustable)	8bar - 11bar (unadjustable)	116 - 160 psi (unadjustable)
IP at max tank pressure	840 – 860 kPa (adjustable)	8.4bar - 8.6bar (adjustable)	122 - 125 psi (adjustable)
IP at empty tank pressure	>750 kPa - < 1000 kPa	> 7.5 bar - < 10 bar	>109 psi - < 145 psi
Property 2nd stage	Setting SI units	Setting common units	Setting US units
CP (cracking pressure)	274 Pa to 392 Pa	28 to 40 mm.w.c	1.1 to 1.6 inch of water

Method for regulators cleaned for EAN40 and oxygen use

⚠ Unless you do have access to an oxygen cleaned test station, you must ensure you do not re-contaminate the regulator when doing the final adjustment and setting. Re-contamination can be caused by e.g. contaminated test gas, contaminated gauge fittings, contaminated regulator connection, contaminated test station pipings etc.

FIRST STAGE SETTING:

- 1) Slowly open cylinder valve
- 2) Check IP
- 3) Close valve
- 4) Purge
- 5) Adjust IP (1/2 turn = 1.5 bar)
- 6) Open valve
- 7) Check IP (loop to 3)
- 8) Close valve
- 9) Purge



SECOND STAGE SETTING:

- 1) Open valve
- 2) Check cracking pressure
- 3) Adjust cracking pressure
- 4) Close valve
- 5) Purge



Method for all other regulators

SYSTEM CHECK:

- 1) Open left valve 20 bar
- 2) Close left valve 20 bar
- 3) Purge



FIRST STAGE SETTING:

- 1) Open right valve HP (200-300bar)
- 2) Purge
- 3) Check IP (go to 9 if OK)
- 4) Close right valve
- 5) Purge
- 6) Adjust IP (1/2 turn = 1.5 bar)
- 7) Open right valve
- 8) Check IP (loop to 4)
- 9) Close right valve
- 10) Purge
- 11) Open left valve (20 bar)
- 12) Check IP
- 13) Close left valve
- 14) Purge



SECOND STAGE SETTING:

- 1) Open either left or right valve, whichever gave the lowest IP
- 2) Check cracking pressure
- 3) Adjust cracking pressure
- 4) Close valve
- 5) Purge



ADJUST THE 2ND STAGE TO 28-40 MM.W.C.

1) Hold the mouthpiece-part of the cracking pressure gauge tight to the outlet of the 2nd stage

2) Take a few rather slow and long inhalations from the mouthpiece part and simultaneously check the pressure gauge needle. It shall during inhalation reach a maximum of 28-40 mm.w.c, and at the end of the inhalation decrease again. If the reading is too high, unscrew the stopscrew as shown in the illustration below-right. Screw the valve tube away from the diaphragm as shown in illustration to the right. If the reading is too low, screw the valve tube towards the diaphragm. Once the reading is correct tighten the stopscrew and then doublecheck the reading.

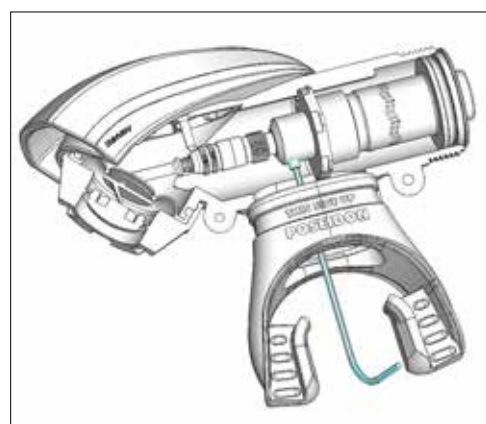

3) Alternatively: immerse the 2nd stage as shown in the illustration. A sizzling sound from the servo-valve opening shall occur within the two markings.

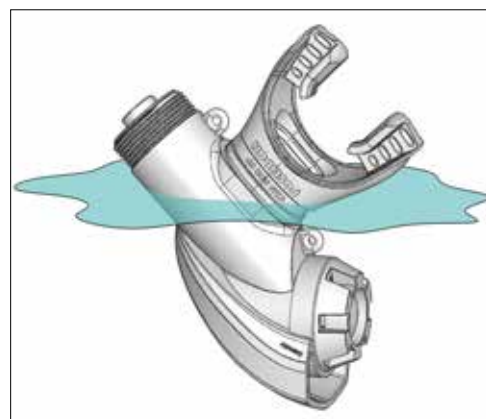
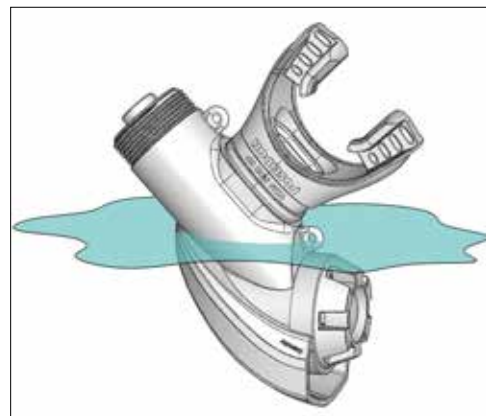
**TIP!**

Some divers like the setting extremely light, and some prefer a higher cracking pressure. Ask your customer. Technically, Xstream can be adjusted from 0 mm.w.c to > 100 mm.w.c. The risk for a free flow increases with decreasing cracking pressure. Below 25 mm.w.c in a certain attitude (exhalation diaphragm the shallowest and inhalation diaphragm the deepest), the regulator inhalation valve will stay permanently open, bubbling. Above 40 mm.w.c the breath doesn't feel good.

Tam nuntum entimultorum iam, in vessedii fica seris etilium heberorem consum

8. Technical data

Torque table

Part subject to torque wrench use	Newton Meter	Inch Pounds	Foot Pounds	Kilogram Meter
	Nm	Inch-lbs	Ft-lbs	Kgm
Blind screws	6 +/- 1	53 +/- 9	4.4 +/- 0.7	0.6 +/- 0.1
First stage connection stem to body	30 +/- 2	265 +/- 18	22 +/- 2	3 +/- 0.2
Centre piece	3 +/- 1	27 +/- 5	2.2 +/- 0.4	0.3 +/- 0.05
Lower centre piece	3 +/- 1	27 +/- 5	2.2 +/- 0.4	0.3 +/- 0.05
2 nd stage	3 +/- 1	27 +/- 5	2.2 +/- 0.4	0.3 +/- 0.05
Hose to 1 st stage	6 +/- 1	53 +/- 9	4.4 +/- 0.7	0.6 +/- 0.1
Cover screws 1 st stage	6 +/- 1	53 +/- 9	4.4 +/- 0.7	0.6 +/- 0.1
Valve house nut	3 +/- 1	27 +/- 5	2.2 +/- 0.4	0.3 +/- 0.05
Servo valve	Firm by hand	Firm by hand	Firm by hand	Firm by hand
Hose to 2:nd stage	Firm by hand	Firm by hand	Firm by hand	Firm by hand

Product data

General:		
Maximum Operational depth	Certified to 200 m (656 ft)	
Typical Work of Breathing 50m on air, 62.5 l/min	1.5 J/l (see diagrams below)	
Typical Work of breathing 200m on Trimix, 62.5 l/min	1.7 J/l (see diagrams below)	
Approved gas	Dive	Air / Trimix
	Deep	Air / Trimix / EAN 40*
	Duration, EN 144-3	Air / EAN 50 / 99,95% Oxygen
	Deco, EN 144-3, Oxygen	Air / 99,95% Oxygen
Maximum working pressure	300 bar (4351 psi)	
Cold water performance	Exceeding EN 250 requirements for cold water use	
Approvals	Type Approved acc. to EU Directive Personal Protective Equipment 89/686/EEC	
Applicable Performance Standards	EN 738-1, clause 6.6, 6.6.2 NORSOK U-101 clause 5.2-5.5, 5.9 EN 250:2000	
Cleaned to hydrocarbon levels < 50mg/m ² & particle level X	Dive	No
	Deep	No
	Duration/EN 144-3	Yes
	Deco/Oxygen	Yes
O-ring materials	Dive	Nitrile, EPDM, Viton
	Deep	Nitrile, EPDM, Viton
	Duration/Oxygen/EN 144-3	Viton, EPDM, Nitrile
	Deco/EN 144-3	Viton, EPDM, Nitrile
Lubricants	Poseidon 1; BAM appr. 270 bar @ 100°C Poseidon 2; BAM appr. 140 bar @ 100°C Poseidon R; silicone oil.	
Colour	Dive	Grey
	Deep	Black
	Duration/EN 144-3	Green
	Deco/Oxygen	White
	Octopus	Yellow
Warranty	24 months (if serviced)	
2 nd stage		
Flow Rate	>2150 l/min STPD (>76 scfm)	
Inner Volume (dead space)	49.5 ml (3 in ³)	
Weight	152 g (5.4 oz)	
Technique	Upstream servo-valve	
Safety valve opening pressure	18 +/- 1 bar (261 +/- 14 psi)	
Swivelling	Around axis, can be used either side	
Material	ASA, Brass, TPU, Silicone, PU	
Venturi assist	Automatic	
Inhalation control	Automatic	
Surgical cord	Silicone	
Dismountable w/o tools	Yes	
Anatomic Mouthpiece	4532 Poseidon AIR	

*Regulators and 1st stages with serial number 1500001 or higher or regulators and 1st stages that has been serviced with the EAN40 service kit.

1st stage		
Flowrate (l/min)	>4000 l/min (>141 scfm)	
Nominal inter-stage pressure	8.5 bar (123 psi)	
Weight (with 70cm hose)	Deep Duration/EN 144-3 Deco/EN 144-3	920 g
	Dive Deep 90 Dur. 90/EN 144-3	1100 g
Anti-Freeze protection	Built in T.D.A	
Technique	Rolling diaphragm	
Valve technique	Ball valve	
Seat material	Zytel	
Test pressure	450 bar (6526 psi)	
Ports*	Dive	5 IP (UNF 3/8") / 2 HP (UNF 7/16")
	Deep Duration/EN 144-3 Deco/EN 144-3	4 IP (UNF 3/8") / 1 HP (UNF 7/16")
	Deep 90 Dur. 90/Oxygen/EN 144-3	5 IP (UNF 3/8") / 2 HP (UNF 7/16")
Connection	Dive	DIN 477, G5/8" – Yoke adapter available
	Deep	DIN 477, G5/8" – Yoke adapter available
	Duration	DIN 477, G5/8" – EN 144-3 (upgradeable)
	Duration & Oxygen EN 144-3	EN 144-3/M26x2
	Deco	DIN 477, G5/8" – EN 144-3 (upgradeable)
Deco EN 144-3	EN 144-3/M26x2	
Material	Brass, plastics, stainless steel	
Hose		
Standard lengths hose	0.7 m (2.3 ft) 0.9 m (3 ft) 1.6 m (5.2 ft) 2.15 m (7 ft)	
Burst pressure	>100 bar (1450 psi)	
Pull strength	>1000 Newton (225 lbf)	
Material	Reinforced NBR/SR *	
Safety inspection holes	Both ends	
Wear protecting crimps	Both ends	
Oxygen cleaned	Available	

Some of the older models of the bottom/side mounted Xstream had 2 IP and 1HP/3 IP 1HP ports. The specified ports for the different models are available from 2005

Conversion tables

Known	Unknown	Multiply by
Bar	psi	14.5
Psi	bar	0.07
mm.w.c	mbar	0.1
mbar	mm.w.c	10
litre	ft ³	0.0353
ft ³	litre	28.32
m	ft	3.28
ft	m	0.305
Nm	poundfoot	0.7375
Poundfoot	Nm	1.356

Performance

Work of breathing

The diagram to the right show a calculated graph for Work of Breathing in Joules/litre at $Q_{average} = 62.5$ litres/min. The equation behind it, is extracted from hundreds of tests, from which coefficients for gas dependency, average flow dependency, and depth dependency is calculated.

Its maximum inaccuracy is within +/- 10%

The equation assumes the most dense gas possible to safely breath is used, i.e. a maximum tolerable pO_2 , pN_2 at any depth. Adding more Helium will lower the figures.

It is important to understand that this equation does not apply to any other regulator, since the coefficients and characteristics are strongly dependent on the regulator construction.

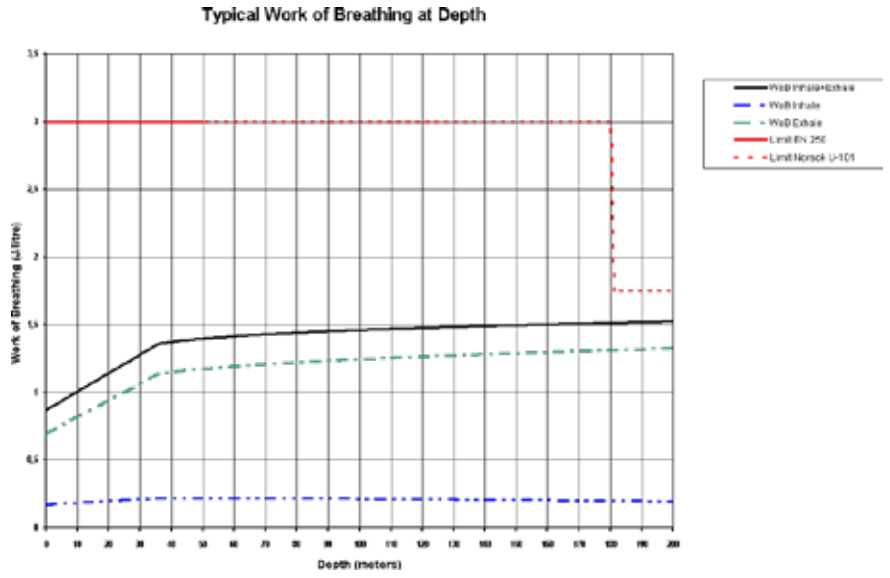

Breathing curve

The diagram below shows a breathing curve for Xstream.

DEMAND REGULATOR PERFORMANCE

- ANSTI - POSEIDON - ANSTI -

CERTIFICATE REFERENCE : 0304 5 2384

DATE : 02-04-2003 TIME : 14:47:10

EQUIPMENT
 REGULATOR TYPE : xstream deep 90
 SERIAL NUMBER :
 INTERSTAGE PRESSURE : 8.6 bar.g (SURFACE/STATIC)

CONDITIONS OF TEST
 ROOM TEMPERATURE : 22.0 C
 WATER TEMPERATURE : 20.3 C
 EXHALE TEMPERATURE : 21.4 C
 HP SUPPLY PRESSURE : 50 bar.g
 TIDAL VOLUME : 2.50 litre BREATH RATE : 25.29 bpm
 VENTILATION RATE : 63.2 lpm

RESULTS
 INHALE PRESSURE = 6.66 mbar (LIMIT = 25 mbar)
 INHALE POS PRESSURE = 2.36 mbar (LIMIT = 5 mbar)
 EXHALE PRESSURE = 15.90 mbar (LIMIT = 25 mbar)
 EXT WORK OF BREATHING = 1.19 J/l (LIMIT = 3.0 Joules/litre)
 INHALE WORK = 0.14 J/l
 POS INHALE WORK = 0.01 J/l (LIMIT = 0.3 Joules/litre)
 EXHALE WORK = 1.04 J/l

PRESSURE - VOLUME DIAGRAM AT DEPTH OF : 51.2 msw (168 fsw)

The diagram shows two pressure-volume curves. The top curve is labeled "EXHALE" and shows pressure in mbar on the y-axis (0 to 25) and volume in litres on the x-axis. The curve starts at ~15 mbar, rises to a peak of ~16 mbar, and then falls back to ~15 mbar. The bottom curve is labeled "INHALE" and shows pressure in bar on the y-axis (0 to 6) and volume on the x-axis. The curve starts at ~2 bar, rises to a peak of ~2.5 bar, and then falls back to ~2 bar.

IP - U
 IP MAX : 12.6 Bar.g
 IP MIN : 10.7 Bar.g

REMARKS :

RDTF-9906 -

9. Oxygen statement

The Poseidon Xstream Deco, Duration, Duration90 and Oxygen are all approved for use with gaseous oxygen up to 99.95 % purity at maximum 300 bar supply pressure and a maximum gas temperature of 60°C

Using gaseous mixtures containing oxygen at high pressure always presents a certain level of risk for equipment failure due to combustion. Greater concentration oxygen, greater pressure, greater temperature, respectively represents factors that contributes to increase the mentioned risk.

In diving operations, the use of oxygen is essential for the human metabolism. In addition, oxygen concentration levels greater than in air, can improve safety, especially but not only, by lowering the risk for DCS and Nitrogen narcosis.

Therefore, Poseidon has taken every precaution using "state of the art" technology, expertise, industrial standards, and knowledge to lower the risk as far as possible. Both Xstream Deco and Xstream Duration are engineered for oxygen use, assembled and cleaned in a clean room environment, made up by materials chosen to expose lowest possible risk x failure-effect product, and are tested and approved for oxygen use.

It is strictly prohibited to use the Poseidon Xstream Deco/Duration with oxygen (ref. "definitions") without being fully trained and certified in the use of oxygen by a recognised training agency. Failure to have such training and certification could lead to death or serious personal injury.

It is likewise absolutely essential that the end user strictly follows the mandatory guidelines given in the users manual for the Xstream models. Regular maintenance, servicing and cleaning is a prerequisite for keeping the risk as low as possible.

Servicing and cleaning must be carried out by an authorised oxygen service dealer. Poseidon has developed and verified a servicing and cleaning method, which guarantee acceptable levels of contaminations. Poseidon can not be held responsible for the effects of other un-verified cleaning and servicing methods.

Failure to adhere to these mandatory requirements transfers the responsibility to the owner.

APPENDIX A

FAQ(T)'s

What shall be used, viton or nitrile?

In short, viton is less likely to ignite but if it does the fumes are extremely toxic. Nitrile is more likely to ignite and releases more heat energy than viton, but the fumes are less toxic. Nitrile has normally better mechanical properties, i.e. it is a better and more reliable seal. Therefore, the risk for, and the consequences of either a failure because of ignition or a loss of seal, determines whether viton or nitrile shall be used.

What about the 40% rule?

In the past some claimed that using gasses containing less than 40% oxygen did not require any special procedures such as e.g. oxygen cleaning. Since it is only a matter of what level of risk that can be accepted, and Poseidon's standpoint is to lower the risk as far as possible for our customers safety,

Xstream Deep 90 regulators and 1st stages with serial number 1500001 and higher are delivered "Nitrox Ready" from the factory. It means that all o-rings are approved for use with enriched gas according to EAN40 and only oxygen compatible lubrication is used. To keep the regulator "Nitrox Ready", a EAN40 service kit must be used and cleaning and lubrication instructions in this service manual must be followed.

Older Xstream Deep regulators and 1st stages can be cleaned to achieve "Nitrox Ready" status using the EAN40 service kit and EAN40 service instructions in this service manual.

Upstream valve and sieze of gas?

The servo valve of the Xstream (and Jetstream) is an upstream opening valve. Because of its small size, an extremely small force is required to crack it open and thereby allow the main valve to open. Even if there is a first stage failure increasing the Interstage pressure, the Interstage pressure will never be greater than twice the originally set IP because of the OPV. In this situation, the cracking pressure will be doubled, but still very small why the regulator will work normally.

Unadjustable, will it keep its setting?

Spontaneous alteration of setting is most commonly due to fatigue of springs. Significant fatigue only occur if the spring is stressed beyond its plastic deformation threshold. A correctly chosen spring will therefore not fatigue and keep its setting.

Can I use Christo-Lube instead?

As per 31/1 2003 Christo-Lube 111 is approved for use with 100% oxygen to 110 bar at 60°C, which is less than the maximum working pressure of Xstream Deco and can therefore not be used. Poseidon 1 Grease is approved for 100% oxygen to 270 bar at 100°C.

Can I put a Jetstream 2nd stage on an Xstream 1st stage?

Yes.

Can I put a Cyklon 5000 2nd stage on an Xstream 1st stage?

Yes. The Cyklon 5000 2nd stage require an IP at 11.5 bar which can only be set with a Xstream 1st stage that has an adjustment screw. See Cyklon X.

What is the expected service life of the servo valve?

If handled in accordance with the instructions given in the users manual, it is not something that should be expected to need any replacement. The most common problem is ingress of water due to immersion of an unpressurised regulator. In such case, salt crystals can form inside the servo valve and create a minor leakage.

Why do Poseidon refer to NORSOK U-101 TBD?

NORSOK U-101 is a Norwegian off-shore standard for testing diving equipment's performance down to 400m (1312 ft) depth. Its requirements put greater demands on breathing resistance than EN 250 does.

Why isn't older Xstream marked EN 250?

EN 250 requires a limitation in use to maximum 50m depth. Xstream is tested and fulfil all requirements of the EN 250, except for it is not limited to 50m, but to 200m depth

APPENDIX B

Fundamental oxygen risks comprehension

For a fire to occur, three elements must be present. A fuel, an oxidiser, and an ignition source. If any of these three is non present, combustion cannot take place. All regulators being used with a gas containing any percentage oxygen, exhibits all these elements and therefore the risk of a fire is present – ranging from extremely low risk to extremely high risk. The ignitability of the fuel, the concentration of oxygen, and the number of ignition sources and their likelihood to occur determines the level of risk exposed.

Everything can combust in an oxygen rich atmosphere, i.e. all materials can be regarded as fuels. Polymers and organic materials are oftenly more easily ignitable than metals, why they shall be avoided as far as possible in a regulator intended for oxygen rich mixtures, in order to lower the risk for combustion.

Gaseous oxygen is a strong oxidiser. The higher concentration, the higher temperature, and the higher pressure – the greater its oxidising properties.

What you as a regulator service technician can do to reduce the risk, is to remove the ignition sources.

- Particulate
- Auto ignition
- Electrical sparks
- Adiabatic Compression
- Heat
- Frictional heat
- Resonance (heat)

Ideally, if you could remove them all, there would be no risk for combustion.

Particulate material can ignite in at least two ways. A small particulate travelling at high speed in a gaseous stream can, when it hits a surface, create either a spark or transfer enough energy to trigger the absorbing materials auto ignition temperature. Or second, since a cluster of particulate material exhibits a large surface area, it can pick up e.g. resonance heat more effectively and thereby reach its own AIT. Particulates must therefore be removed effectively.

All materials have a threshold temperature upon reached the material will start to burn automatically, the Auto Ignition Temperature, AIT. The AIT depends on oxygen concentration, such as at a higher concentration the lower threshold. Hydrocarbons (oil, fingerprints, grease) have a very low AIT, and are almost certain to combust in an oxygen rich environment at high pressures.

Combustion, if it occurs, can be anything from unnoticeable to catastrophic. A low mass of e.g. some Nylon-like plastic materials will only produce fumes containing carbon-dioxid and water. Other plastics, e.g. viton, will produce hydroflouric acids, which even in extremely low concentrations can kill a diver if inhaled. Viton has a significantly higher AIT than Nylons, why it is far less likely to burn if compared in exactly the same situation. But the effects if it happens in a regulator is far worse.

Different materials when burning releases different amounts of energy. Hydrocarbons have a high heat of combustion. The produced heat can in turn act as an ignition source for less ignitable materials, producing what's referred to as a kindling chain reaction. Thereby, the presence of materials with low AIT and high HC, can ignite the nextcoming part downstream, which in turn possibly can ignite...etc.

There are no level of percentage of oxygen which can be guaranteed as safe. There are only factors which increases or decreases the risk for combustion.

The O₄ concept

Poseidon has introduced the O₄ concept, which stands for oxygen engineered, oxygen compatible, oxygen clean, and oxygen approved.

- O₁ In short, oxygen engineered is taking every step to lower both the risk for combustion and the possible effect of combustion. The design must reduce the number of ignition sources, allow effective maintenance and cleaning, materials must be selected as to break kindling chain reactions, constructed to minimise effects of compression shocks etc.
- O₂ Oxygen compatible is selecting materials which have the best combination of AIT, HC, OI, and the severity of a possible failure for its function in the sytem.
- O₃ Oxygen clean means that either a component or a complete system is cleaned from especially hydrocarbons and particulate to a level which gives an acceptable risk for ignition.
- O₄ Oxygen approved means the product has passed tests conducted by independent organisations according to international standards.

APPENDIX C

Intermediate pressure clarification

Guidance: Understanding Intermediate Pressure in Poseidon Xstream First Stages

This text aims to provide a clear and educational explanation of why variations in intermediate pressure are completely normal and within acceptable limits. It also explains the purpose of intermediate pressure and how it impacts regulator performance and safety.

What is intermediate pressure – and why is it important?

The intermediate pressure is the pressure delivered by the first stage to the second stage. Its primary purpose is to protect and ensure the correct function of the second stage, not to maintain a fixed, exact value.

Poseidon's Xstream first stage requires a minimum of 7.5 bar (109 psi) of intermediate pressure to seal properly when pressurized. If the intermediate pressure exceeds 10 bar (145 psi), certain soft components (such as the 3440 valve insert) inside the Xstream and Jetstream second stages may risk being damaged. Therefore, we have defined an acceptable intermediate pressure range of 7.5 – 10 bar (109 – 145 psi).

(Note: When pairing the Xstream first stage with the Cyklon second stage – a configuration referred to as Cyklon X – the intermediate pressure must be set to 11.5 bar (167 psi), with an acceptable range of 10 – 13 bar (145 – 189 psi), to ensure correct breathing performance. If the intermediate pressure is too low, the Cyklon second stage will be very heavy to breathe from.)

Setting and Measuring Intermediate Pressure

During production, the intermediate pressure is set to an IP of around 8.5 bar (123 psi) at 300 bar (4351 psi) cylinder pressure (or 11.5 bar (167 psi) when configured as Cyklon X).

This target value ensures that, throughout the full cylinder pressure range (from 200–300 bar (2901–4351 psi) down to 20 bar (290 psi)), the regulator will always deliver an intermediate pressure that remains within the safe and functional limits of the connected second stage.

Our internal testing data shows the following (paired with Xstream and Jetstream second stages):

- At high cylinder pressure (200 bar / 2,901 psi), intermediate pressure has ranged between 8.1 – 9.5 bar (118 – 138 psi)
- At low cylinder pressure (20 bar / 290 psi), intermediate pressure has ranged between 7.5 – 9.5 bar (109 – 138 psi)
- None of the 73 tested first stages in this data set showed values outside the acceptable 7.5 – 10 bar (109 – 145 psi) range

NOTE: The exception to these IP settings are the very first generation of Xstream 1st stages, built in 2002-2003, that didn't have an adjustment screw. These 1st stages will have a IP of between 8 - 11 bar (116-160 psi) at max tank pressure. It is recommended that these 1st stages are upgraded to a cap with adjustment screw by applying upgrade kit #4767-KIT.

For correct IP setting, please see table in page 38.

The Tolerance Range Is by Design – Not a Defect

It is important to understand that intermediate pressure is not an absolute value, but rather a range.

Some variation between units and depending on whether the cylinder is at 200 or 300 bar (2901 or 4351 psi), is normal and expected. This does not mean the product is faulty.

In fact, this is a strength of the Xstream design – it is built to operate safely and efficiently across a wide intermediate pressure range.

Leakage

When the 1st stage is pressurized at maximum tank pressure, and the IP has been set, the IP may rise 0,7 bar/ 10 psi within 30 seconds and then stop, and the IP is regarded as ok and the 1st stage is not leaking.

But if the IP rises more than 0,7 bar/10 psi and/or does not stop to rise, the 1st stage is leaking and must be checked/repaired.

APPENDIX D

Cleanroom and oxygen cleaning requirement

Check list

1. Cleanroom / work environment requirements		OK																		
1.1	The work area must be dedicated only for oxygen servicing. Ideally a separate room or at least a space clearly marked out as an oxygen clean area, e.g. by floor marking, signs, and/or screens. Ceiling, walls, and floor shall be non-contaminant producing and be easily cleaned. If the location is not sufficient in this respect, sheets of polyethylene plastic can be taped to fully surround the work area.																			
1.2	The work area must be free from airborne dust and droplets. It shall never be close to areas where machining takes place, compressors are running, or other activities which can produce a mist containing hydrocarbons or other flammable or particulate contaminants.																			
1.3	The work bench shall be sufficient in size as to enable a good organization of equipment, tools and the regulator parts. A clean polyethylene plastic sheet shall be used to protect the work bench. It is recommended to have a roll of plastic sheet at one end of the work bench. Used sheets shall be disposed if there are any signs of contamination.																			
1.4	Items incompatible with oxygen such as e.g. hydrocarbon oil and grease must not be stored or ever used in the area.																			
1.5	Oil, grease, residue, spilled chemicals, and any foreign material which develop in the area shall be cleaned immediately. At least monthly the clean room shall be completely cleaned.																			
1.6	It is recommended to keep cleanroom temperature close to standard room temperature and humidity less than 50%. Since all tools will be kept free from grease, the risk of them rusting increases the higher the humidity.																			
1.7	It is recommended to see to that the work area maintain a slight positive pressure so that the air flow will always be outward from the clean area.																			
1.8	The following activities are absolutely prohibited inside the cleanroom area: <ul style="list-style-type: none"> • Smoking • Eating • The use of car heaters 																			
2. Personnel clothing requirements		OK																		
2.1	The special clothing as described below must not be worn or taken outside the cleanroom.																			
2.2	Lint free gloves shall be worn. Regard everything you touch as contaminated, unless you are sure it is clean. This means you shall replace your gloves if they have been in contact with something you can suspect being contaminated.																			
2.3	In the clean room a hair net and a coverall / laboratory coat shall be worn.																			
2.4	These requirements apply to anyone being in the cleanroom, including visitors and observers.																			
3. Tools and equipment requirements		OK																		
The cleaning procedure as described for the regulator also applies to all tools and equipment used.																				
3.1	All tools and equipment used must be cleaned and kept clean. It must be ensured that tools and equipment from this area is not shared with other servicing locations. Tools used to disassemble the regulator must be regarded as contaminated, and cannot be used for assembly unless they have been cleaned after the disassembly stage. We therefore recommend having two sets of the required tools, one of which is always kept clean.																			
3.2	Tools have to be re-cleaned every month or after 10 serviced regulators, whichever comes first.																			
3.3	An ultra-sonic cleaner Poseidon XXXX shall be used. In addition to the instructions for use and maintenance in the users manual, the bath shall be cleaned with IPA and a lint free mop or lint free paper on a regular basis, or when contamination can be suspected. This is to ensure that a possible trace of an oil-film on the inside of the bath is removed.																			
3.4	The solution in the ultrasonic bath shall be replaced after a) maximum 30 times of use, b) earlier if signs of contamination is present, c) at least every fourth week.																			
4. Rinsing water requirements		OK																		
4.1	Water quality must be in level with or better than: <table border="1" data-bbox="145 1182 707 1294"> <tbody> <tr> <td>Chloride ion (ppm)</td> <td>1,0 maximum</td> </tr> <tr> <td>Conductivity ($\mu\Omega/\text{cm}^3$)</td> <td>20 maximum</td> </tr> <tr> <td>Resistivity (cm^3/Ω)</td> <td>50K minimum</td> </tr> <tr> <td>pH</td> <td>6-8</td> </tr> <tr> <td>Visual clarity</td> <td>No turbidity, oil, or sediment</td> </tr> </tbody> </table>	Chloride ion (ppm)	1,0 maximum	Conductivity ($\mu\Omega/\text{cm}^3$)	20 maximum	Resistivity (cm^3/Ω)	50K minimum	pH	6-8	Visual clarity	No turbidity, oil, or sediment									
Chloride ion (ppm)	1,0 maximum																			
Conductivity ($\mu\Omega/\text{cm}^3$)	20 maximum																			
Resistivity (cm^3/Ω)	50K minimum																			
pH	6-8																			
Visual clarity	No turbidity, oil, or sediment																			
4.2	A chemical analysis of the water quality shall be conducted at least annually by an independent laboratory.																			
5. Gas requirements		OK																		
5.1	Gas used for blow-guns and for regulator testing must fulfill the following requirements: <table border="1" data-bbox="145 1375 987 1570"> <thead> <tr> <th colspan="2">Maximum level of:</th> </tr> </thead> <tbody> <tr> <td>CO</td> <td>2 ppm</td> </tr> <tr> <td>CO₂</td> <td>500 ppm</td> </tr> <tr> <td>Water dew point</td> <td>-45°C (-50°F)</td> </tr> <tr> <td>Lubricants (droplets/mist)</td> <td>0.5mg/ m³</td> </tr> <tr> <td>Water</td> <td>35 mg/ m³ 39ppm</td> </tr> <tr> <td>Gaseous hydrocarbons</td> <td>15 ppm</td> </tr> <tr> <td>Condensed hydrocarbons</td> <td>0.1 mg/m³</td> </tr> <tr> <td>Solid particles</td> <td>2 microns</td> </tr> </tbody> </table>	Maximum level of:		CO	2 ppm	CO ₂	500 ppm	Water dew point	-45°C (-50°F)	Lubricants (droplets/mist)	0.5mg/ m ³	Water	35 mg/ m ³ 39ppm	Gaseous hydrocarbons	15 ppm	Condensed hydrocarbons	0.1 mg/m ³	Solid particles	2 microns	
Maximum level of:																				
CO	2 ppm																			
CO ₂	500 ppm																			
Water dew point	-45°C (-50°F)																			
Lubricants (droplets/mist)	0.5mg/ m ³																			
Water	35 mg/ m ³ 39ppm																			
Gaseous hydrocarbons	15 ppm																			
Condensed hydrocarbons	0.1 mg/m ³																			
Solid particles	2 microns																			
5.2	A gas analysis of the gas quality shall be conducted at least annually by an independent laboratory for the gas used to dry cleaned parts.																			
5.3	It is strongly recommended to use filtered air for the purpose of drying and regulator testing.																			
6. Disposal		OK																		
6.1	Disposal of water shall be in accordance with local, state, or federal regulations																			
7. Documentation		OK																		
7.1	The Poseidon Oxygen Service Center must have documented maintenance procedures/routines covering: <table border="1" data-bbox="145 1742 483 1787"> <tbody> <tr> <td>7.1.1</td> <td>Cleanroom cleaning</td> </tr> <tr> <td>7.1.2</td> <td>Tool cleaning</td> </tr> </tbody> </table>	7.1.1	Cleanroom cleaning	7.1.2	Tool cleaning															
7.1.1	Cleanroom cleaning																			
7.1.2	Tool cleaning																			

Issue 3.3

Copyright © Poseidon Diving Systems AB 2005 - 2024

All rights reserved. No parts of this book may be reproduced in any form whatsoever without written permission of the publisher.

Service manual Xstream.